



Inductive Proximity Sensors

Bulletin Numbers 802PR, 871C, 871D, 871F, 871FM, 871L, 871P, 871R, 871T, 871TM, 871 TS, 871Z, 871ZC, 871ZT, 872C, 872L

Topic	Page
Tubular Sensors	
871C Special Purpose	2
871T Stainless Steel Barrel	14
871TM All Stainless Steel	20
871TS Food and Beverage	42
871Z Weld Field Immune	43
871ZT Weld Field Immune	47
872C WorldProx General Purpose	48
Rectangular Sensors	
802PR Limit Switch Style	52
871F Block, Flat Pack, and Puck Style	61
871FM Mini Flat Pack Style	71
871L and 872L Limit Switch Style	78
871P Can Sensors	82
871P VersaCube Multi-position	86
Cylinder Sensors	
871D Cylinder Positioning	94
871D WorldClamp	96
Ring and Slot Sensors	
871R Ring Style	98
871S Slot Style	100

Summary of Changes

This publication contains updated 871TM sensor correction factors for copper targets on pages [20](#), [30](#), [32](#), [35](#), and [38](#).



871C 2-wire AC Full Featured Tubular Sensors

Plastic Face/Threaded Nickel-plated Brass Barrel



871C AC Cable Style
18 mm and 30 mm



871C AC Mini Quick-disconnect Style
12 mm, 18 mm, and 30 mm



871C AC Micro Quick-disconnect Style
12 mm, 18 mm, and 30 mm

Specifications

Attribute	12 mm	18 mm and 30 mm
Load Current	5...200 mA	5...250 mA
Inrush Current (one cycle)	≤2 A	≤4 A
Leakage Current	≤1.9 mA @ 120V AC	
Operating Voltage	20...250V AC	
Voltage Drop	≤10V @ 5...200 mA	≤10V @ 5...250 mA
Repeatability	≤10% at constant temperature	
Hysteresis	10% typical	
Protection Type	False pulse, transient noise, short circuit, overload (trigger at 250 mA typical)	False pulse, transient noise, short circuit, overload (trigger at 320 mA typical)
Certifications	UL Listed, CSA Certified, and CE Marked for all applicable directives	
Enclosure Type Rating	NEMA 1, 2, 3, 3R, 4, 4X, 6, 6P, 12, 13; IP67 (IEC529)	
Housing Material	Nickel plated brass barrel	
Connection Type	<ul style="list-style-type: none"> Cable: 2 m (6.5 ft) length, 2-conductor PVC Quick-disconnect: 3-pin micro, 3-pin mini 	
Status Indicator	<ul style="list-style-type: none"> Red: Output energized/short circuit (flashing) Green: Power 	
Operating Temperature	-25...+70 °C (-13...+158 °F)	
Shock	30 g (1.06 oz), 11 ms	
Vibration	55 Hz, 1 mm (0.04 in.) amplitude, 3 planes	

Correction Factors

Target Material	Correction Factors
Steel	1.0
Stainless Steel	0.9
Brass	0.5
Aluminum	0.45
Copper	0.4

Approximate Dimensions [mm (in.)]

Cable Style

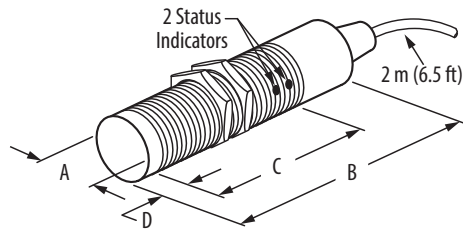

Wiring Diagrams

Normally Open

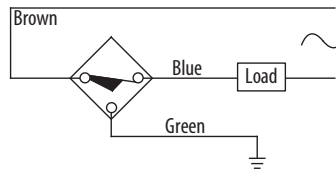

Normally Closed

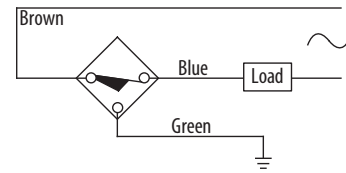

Note: Load can be switched to brown wire.

Thread Size	Shielded	mm (in.)			
		A	B	C	D
M12 x 1	Yes	12.0 (0.47)	78.99 (3.11)	47.24 (1.86)	0.8 (0.03)
M18 x 1	Yes	18.0 (0.71)	74.68 (2.94)	61.6 (2.43)	
M30 X 1.5	Yes	30.0 (1.18)	77.52 (3.05)	64.31 (2.53)	

Mini QD Style

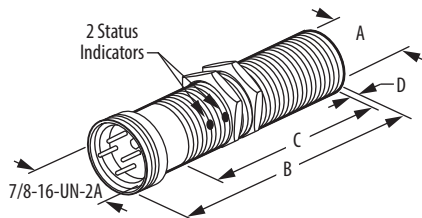

Normally Open or Normally Closed

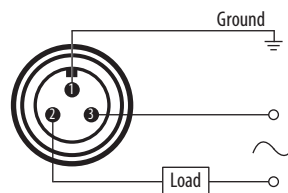

Note: No ground wire on 12 mm. Attach housing to ground.

Note: Load can be switched to pin 3.

Thread Size	mm (in.)		
	A	B	C
M12 x 1	12.0 (0.47)	93.45 (3.68)	46.08 (1.81)
M18 x 1	18.0 (0.71)	75.82 (2.99)	53.9 (2.12)
M30 X 1.5	30.0 (1.18)	86.66 (3.41)	64.31 (2.53)

Micro QD Style

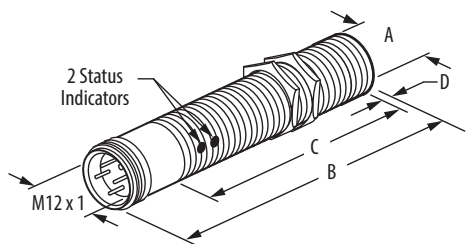

Normally Open or Normally Closed

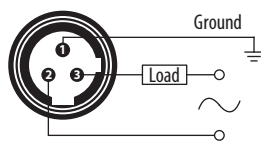

Note: No ground wire on 12 mm. Attach housing to ground.

Note: Load can be switched to pin 2.

Thread Size	mm (in.)		
	A	B	C
M12 x 1	12.0 (0.47)	90.42 (3.56)	46.99 (1.85)
M18 x 1	18.0 (0.71)	83.54 (3.29)	61.6 (2.43)
M30 X 1.5	30.0 (1.18)	86.00 (3.39)	64.31 (2.53)

871C 2-wire AC Plastic Barrel Tubular Sensors

Plastic Face/Threaded



871C AC Cable Style
18 mm and 30 mm

Specifications

Attribute	18 mm	30 mm
Load Current	≤180 mA	≤300 mA
Inrush Current (one cycle)	≤1 A	≤3 A
Leakage Current	≤1.7 mA	
Operating Voltage	24...250V AC	
Voltage Drop	≤11V	
Hysteresis	≤20% typical	
Protection Type	Transient noise	
Certifications	CE Marked for all applicable directives	
Enclosure Type Rating	NEMA 1, 2, 3, 4, 4X, 12, 13; IP67 (IECS29)	
Housing Material	Plastic barrel	
Connection Type	Cable: 2 m (6.5 ft) length, 2-conductor PVC	
Status Indicator	Red: Output energized	
Operating Temperature	-25...+55 °C (-13...+131 °F)	
Shock	30 g (1.06 oz), 11 ms	
Vibration	55 Hz, 1 mm (0.039 in.) amplitude, 3 planes	

Correction Factors

Target Material	Correction Factors
Steel	1.0
Stainless Steel	0.7...0.8
Brass	0.4...0.5
Aluminum	0.3...0.4
Copper	0.3...0.4

Approximate Dimensions [mm (in.)]

Cable Style

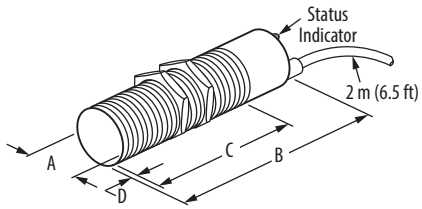

Wiring Diagrams

Normally Open

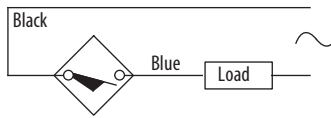

Note: Load can be switched to black wire.

Normally Closed

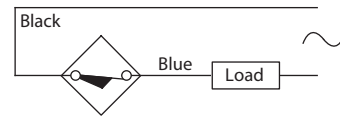

Thread Size	Shielded	mm (in.)			
		A	B	C	D
M18x 1	Yes	18.0 (0.71)	81.0 (3.19)	61.0 (2.40)	2.0 (0.08)
	No ⁽¹⁾				
M30 X 1.5	Yes	30.0 (1.18)	81.0 (3.19)	61.0 (2.40)	2.0 (0.08)
	No ⁽¹⁾				

(1) Unshielded proximity sensors require a metal-free zone around the sensing face. Any metal immediately opposite the sensing face must be no closer than three times the rated nominal sensing distance of the sensor.

871C Analog Output, 3-wire DC Tubular Sensors

Plastic Face/Nickel-plated Brass Barrel



871C Cable Style
12 mm, 18 mm, and 30 mm

Specifications

Attribute	12 mm	18 mm	30 mm
Analog Output	0...10V Sourcing		
Load Current	5 mA		
Operating Voltage	18...30V DC		
Repeatability	≤1%		
Ripple	10%		
Slew Speed	1.0 V/ms	0.7 V/ms	0.1 V/ms
Δ Output/Δ Distance	0.25 mm/V	0.375 mm/V	0.875 mm/V
Linearity Tolerance	6.25%		
Temperature Drift	±0.3V		
Protection Type	Transient noise, reverse polarity, short circuit, and overload		
Certifications	CE Marked for all applicable directives		
Enclosure Type Rating	NEMA 1, 2, 3, 4, 12, 13; IP67 (IEC529)		
Housing Material	Nickel-plated brass barrel, plastic face (PBT)		
Connection Type	Cable: 2 m (6.5 ft) length, 3-conductor PVC		
Status Indicator	None		
Operating Temperature	-25...+70 °C (-13...+158 °F)		
Shock	30 g (1.06 oz), 11 ms		
Vibration	55 Hz, 1 mm amplitude, 3 planes		

Correction Factors

Target Material	Correction Factors
Steel	1.0
Stainless Steel	0.7...0.8
Brass	0.4...0.5
Aluminum	0.3...0.4
Copper	0.2...0.3

Approximate Dimensions [mm (in.)]

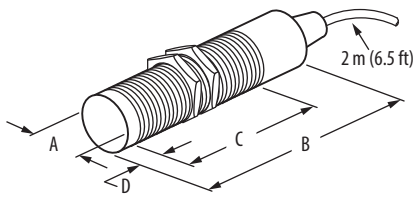

Thread Size	mm (in.)			
	A	B	C	D
12 mm	12.0 (0.47)	81.0 (3.15)	58.0 (2.28)	12 (0.47)
18 mm	18 (0.71)		70 (2.75)	
30 mm	30.0 (1.18)			

Wiring Diagrams

12 mm

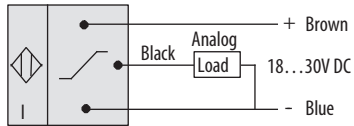

18 mm

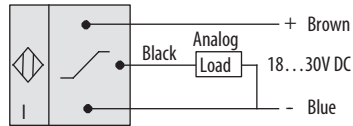

30 mm

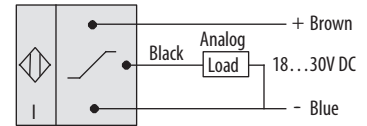

Nominal Output

12 mm

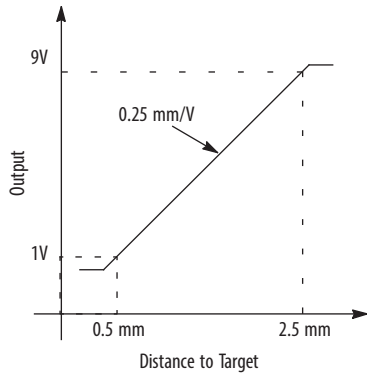

18 mm

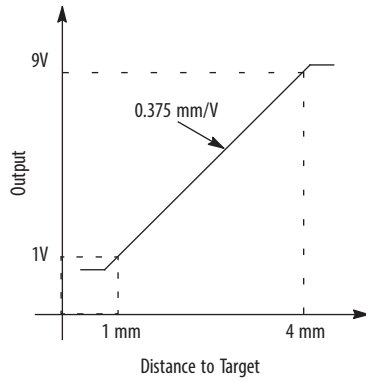

30 mm

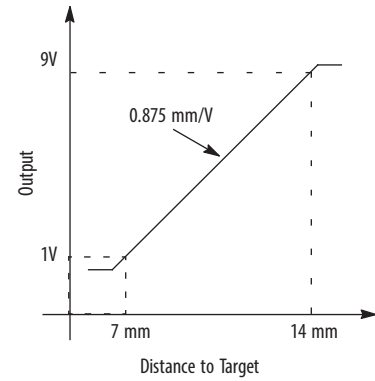

871C 2-wire NAMUR Intrinsically Safe, Cable Style Tubular Sensors

Nickel-plated Brass Barrel, Plastic Face



871C NAMUR Cable Style
8 mm, 12 mm, 18 mm, and 30 mm



871C NAMUR Micro Quick-disconnect Style
8 mm, 12 mm, 18 mm, and 30 mm

Specifications

Attribute	8 mm, 12 mm, 18 mm, and 30 mm
Output Type	NAMUR (conforms to DIN 19 234)
Load Current, Nom.	<1 mA (target present), >3 mA (target absent)
Operating Voltage	5...15V DC (8.2V DC nom., Ri = 1 kohm, DIN 19 234)
Ripple	5%
Repeatability	<10%
Hysteresis	10% typical
Protection Type	Reverse polarity, false pulse, transient noise, short circuit, and overload
Certifications	FM Approved: <ul style="list-style-type: none"> • Class I, II, III; Divisions 1, 2; Groups A, B, C, D, E, F, G • Class I; Zone 0, 1, 2; Groups IIC, IIB, IIA; T6; CSA Certified • Class I, II, III; Divisions 1, 2; Groups A, B, C, D, E, F, G • Class I; Zone 0, 1, 2; Groups IIC, IIB, IIA; CE Marked for all applicable directives
Enclosure Type Rating	NEMA 4, IP67 (IEC529)
Housing Material	Nickel-plated brass barrel, plastic face
Connection Type	<ul style="list-style-type: none"> • Cable: 2 m (6.5 ft) length, 2-conductor #22 AWG PVC • Quick-disconnect: 4-pin micro style
Status Indicator	None
Operating Temperature	-25...+60 °C (-13...+140 °F)
Shock	30 g (1.06 oz), 11 ms
Vibration	55 Hz, 1 mm amplitude, 3 plane

Correction Factors

Target Material	Correction Factors
Steel	1.0
Stainless Steel	0.7...0.8
Brass	0.4...0.5
Aluminum	0.3...0.4
Copper	0.2...0.3

Entity Parameters

Sensor			Barrier
V_{max}	16V	\geq	V_t
I_{max}	60 mA	\geq	I_t
C_l	150 nF	\leq	C_a
L_l	200 μ H	\leq	L_a

IMPORTANT Operating parameters must be adhered to.

Approximate Dimensions [mm (in.)]

Cable Style

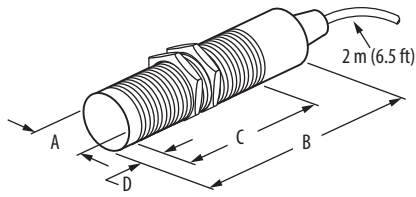

Wiring Diagrams

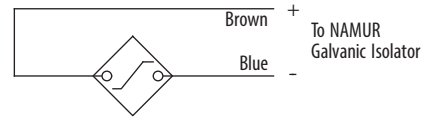

Thread Size	Shielded	mm (in.)		
		A	B	C
M8 X1	Yes	8.0 (0.31)	30.0 (1.18)	—
	No			5.0 (0.20)
M12 X1	Yes	12.0 (0.47)		—
	No			6.0 (0.24)
M18 X1	Yes	18.0 (0.71)	—	
	No		8.0 (0.31)	
M30 X1.5	Yes	30.0 (1.18)	40.0 (1.57)	—
	No		—	12.0 (0.47)

Micro QD Style

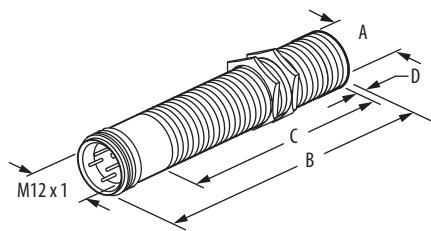

Normally Open

PNP (Sourcing)



Thread Size	Shielded	mm (in.)			
		A	B	C	D
M8 X1	Yes	8.0 (0.31)	50.0 (1.97)	28.0 (1.10)	—
	No			23.0 (0.91)	5.0 (0.20)
M12 X1	Yes	12 (0.47)		30.0 (1.18)	—
	No			24.0 (0.94)	6.0 (0.24)
M18 X1	Yes	18.0 (0.71)	30.0 (1.18)	—	
	No		22.0 (0.87)	8.0 (0.31)	
M30 X1.5	Yes	30.0 (1.36)	60.0 (2.36)	40.0 (1.57)	—
	No		—	28.0 (1.10)	12.0 (0.47)

871C 3-wire DC Mini Tubular Sensors

Plastic Face/Small Threaded or Smooth Stainless Steel Barrel 3 mm, 4 mm, and 5 mm



871C NAMUR Cable Style
8 mm, 12 mm, 18 mm, and 30 mm



871C NAMUR Micro Quick-disconnect Style
8 mm, 12 mm, 18 mm, and 30 mm



871C NAMUR Micro Quick-disconnect Style
8 mm, 12 mm, 18 mm, and 30 mm



871C NAMUR Micro Quick-disconnect Style
8 mm, 12 mm, 18 mm, and 30 mm



871C NAMUR Micro Quick-disconnect Style
8 mm, 12 mm, 18 mm, and 30 mm

Specifications

Attribute	3 mm Smooth Barrel and 4 mm Threaded Barrel	4 mm Smooth Barrel and 5 mm Threaded Barrel
Environmental		
Operating Environment	NEMA 1, 2, 3, 4, 12, 13 IP67 (IEC 529)	
Operating Temperature	-25...+70 °C (-13...+158 °F)	
Vibration	55 Hz, 1 mm amplitude, 3 planes	
Shock	30 g (1.06 oz), 11 ms	
Electrical		
Load Current	≤ 100 mA	<200 mA
Leakage Current	≤ 0.1 mA	
Operating Voltage	10...30V DC	
Voltage Drop	≤ 2V	
Repeatability	≤ 5%	
Hysteresis	10% typical	
Protection Type	False pulse, transient noise, reverse polarity, and short circuit	
IO-Link (Enabled on Normally Open, PNP Models Only)		
Protocol	IO-Link V1.0	
Interface Type	IO-Link	
Mode	COM 2 (38.4 kBd)	
Cycle Time 1	10.4 ms, minimum	
SIO (standard I/O)	Supported (pin 4 for either IO-Link or SIO)	
Mechanical		
Housing Material	Stainless steel barrel, polyester face	
Status Indicator	Yellow: Output energized	
Status Indicator (IO-Link Mode)	Solid yellow: Sensor in IO-Link mode	
Connection Type	Pico™ QD (M8), 2 m (6.6 ft) cable, pico with lead	

Correction Factors

Sensor Type/ Target Material	3 mm Diameter Smooth		4 mm Diameter Smooth or Threaded		5 mm Diameter Smooth or Threaded	
	0.6 mm Sr	1.0 mm Sr	0.8 mm Sr	1.5 mm Sr	1 mm Sr	1.5 mm Sr
Steel	1	1	1	1	1	1
Copper	0.5	0.45	0.45	0.4	0.45	0.4
Aluminum	0.55	0.5	0.5	0.4	0.5	0.4
Brass	0.65	0.6	0.55	0.5	0.55	0.5
Stainless Steel 304	0.8	0.8	0.8	0.75	0.8	0.75

Switching Frequency

Barrel Diameter [mm (in.)]	Nominal Sensing Distance [mm (in.)]	Switching Frequency [Hz]
3	0.6 (0.02)	5000
	1 (0.04)	3000
4	0.8 (0.03)	5000
	1 (0.04)	3000
	1.5 (0.06)	3000
5	1 (0.04)	5000
	1.5 (0.06)	3000



Approximate Dimensions [mm (in.)]

Cable Style

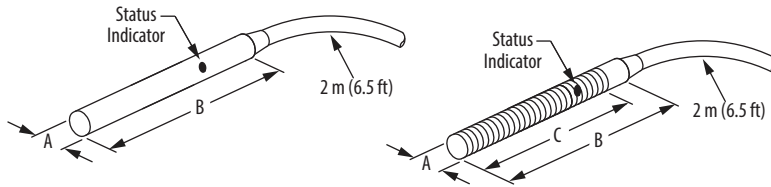

Wiring Diagrams

Normally Open

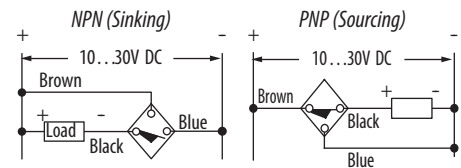

Smooth Diameter	Thread Size	Shielded	[mm (in.)]		
			A	B	C
3.0	—	Yes	3.0 (0.12)	22.0 (0.87)	—
4.0	—		4.0 (0.16)	25.0 (0.98)	—
4.0	M4 X 0.5	Yes	4.0 (0.16)	22.0 (0.87)	19.0 (0.75)
5.0	M5 X 0.5		5.0 (0.20)	25.0 (0.98)	20.0 (0.79)

Pico QD Style

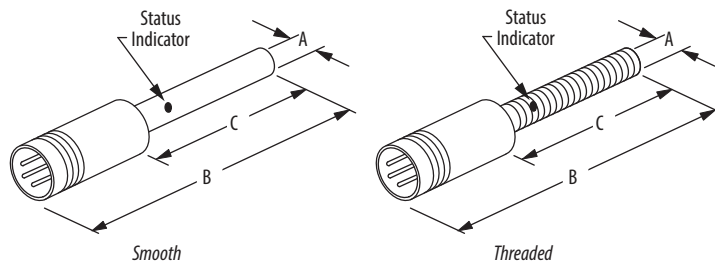

Normally Open

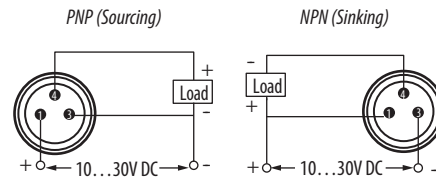

Smooth Diameter	Thread Size	Shielded	mm (in.)		
			A	B	C
4.0	—	Yes	4.0 (0.16)	38.0 (1.50)	19.0 (0.74)
5.0	M5 X 0.5		5.0 (0.20)	38.0 (1.50)	23.0 (0.90)

Pico with Lead Style

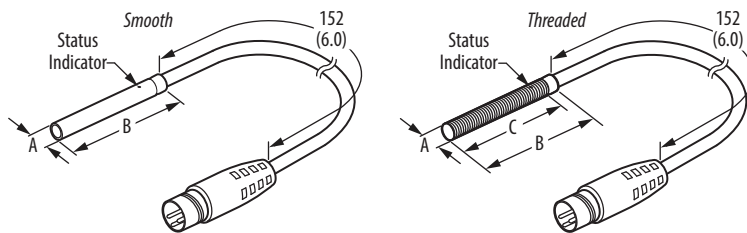

Normally Open

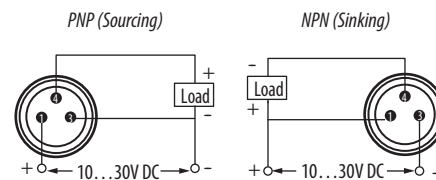

Smooth Diameter	Shielded	mm (in.)		
		A	B	C
3.0	Yes	3.0 (0.1)	22.0 (0.87)	—
4.0		4.0 (0.16)	22.0 (0.87)	19.0 (0.74)

871C 3-wire DC Extended Temperature Tubular Sensors

Plastic Face/Threaded Nickel-plated Brass Barrel



871C DC Cable Style
12 mm, 18 mm, and 30 mm



871C DC Micro Quick-disconnect Style
12 mm, 18 mm, and 30 mm

Specifications

Attribute	12 mm, 18 mm, and 30 mm
Load Current	1...200 mA
Leakage Current	≤10 µA
Operating Voltage	10...30V DC
Voltage Drop	≤2.4V
Repeatability	≤10%
Hysteresis	≤15% typical
Protection Type	False pulse, transient noise, reverse polarity, short circuit, and overload
Certifications	CE Marked for all applicable directives
Enclosure Type Rating	NEMA 1, 2, 3, 4, 12, 13; IP67 (IECS29)
Housing Material	Nickel-plated brass barrel
Connection Type	<ul style="list-style-type: none"> Cable: 2 m (6.5 ft) length, 3-conductor PUR Quick-disconnect: 4-pin micro style
Status Indicator	Orange: Output Energized
Operating Temperature	-40...+100 °C (-40...+212 °F)
Shock	30 g (1.06 oz), 11 ms
Vibration	55 Hz, 1 mm amplitude, 3 planes

Correction Factors

Target Material	Correction Factors
Steel	1.0
Stainless Steel	0.9
Brass	0.5
Aluminum	0.45
Copper	0.4

Approximate Dimensions [mm (in.)]

Cable Style

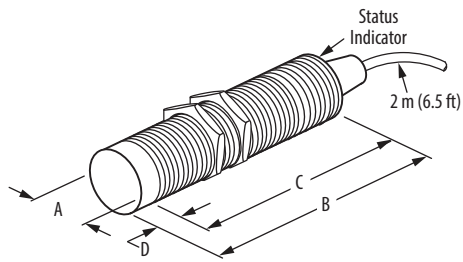

Wiring Diagrams

Normally Open

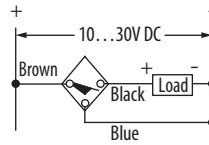

Thread Size	Shielded	mm (in.)				
		A	B	C	D	
M12 X 1	Yes	12.0 (0.47)	40.0 (1.57)	40.0 (1.57)	—	
	No			34.0 (1.34)	6.0 (0.24)	
M18 X 1	Yes			18.0 (0.71)	40.0 (1.57)	—
	No				32.0 (1.26)	8.0 (0.31)
M30 X 1.5	Yes			30.0 (1.18)	40.0 (1.57)	—
	No				28.0 (1.12)	12 (0.47)

Micro QD Style

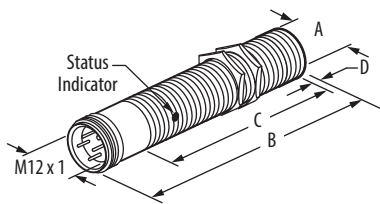

Normally Open

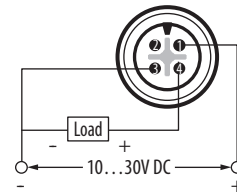

Thread Size	Shielded	mm (in.)				
		A	B	C	D	
M12 X 1	Yes	12.0 (0.47)	60.0 (2.36)	40.0 (1.57)	—	
	No			34.0 (1.34)	6.0 (0.24)	
M18 X 1	Yes			18.0 (0.71)	40.0 (1.57)	—
	No				32.0 (1.26)	8.0 (0.31)
M30 X 1.5	Yes			30.0 (1.18)	40.0 (1.57)	—
	No				28.0 (1.12)	12 (0.47)

871T 3-wire DC Stainless Steel Barrel Tubular Sensors

Plastic Face/Threaded



871C DC Cable Style
12 mm and 18 mm



871C DC Mini Quick-disconnect Style
18 mm

Specifications

Attribute	12 mm	18 mm
Load Current	≤300 mA	≤400 mA
Leakage Current	≤10 µA	
Operating Voltage	10...30V DC	
Voltage Drop	≤1V	
Repeatability	≤10%	
Hysteresis	≤10% typical	
Protection Type	False pulse, transient noise, reverse polarity, short circuit, and overload	
Certifications	UL Listed, CSA Certified, and CE Marked for all applicable directives	
Enclosure Type Rating	NEMA 1, 2, 3, 4, 12 and 13; IP67 (IEC529)	
Housing Material	Stainless Steel 303 barrel	
Connections	<ul style="list-style-type: none"> Cable: 3 m (10 ft) length, 3-conductor PVC Quick-disconnect: 4-pin mini style 	
Status Indicator	Red: output energized	
Operating Temperature	-40...+70 °C (-40...+158 °F)	

Correction Factors

Target Material	Correction Factors
Steel	1.0
Stainless Steel	0.7...0.9
Brass	0.3...0.5
Aluminum	0.3...0.4
Copper	0.3...0.4

Approximate Dimensions [mm (in.)]

Cable Style

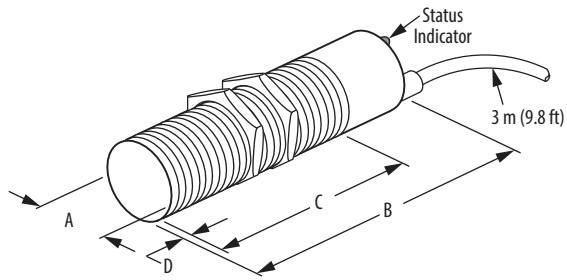

Wiring Diagrams

Normally Open

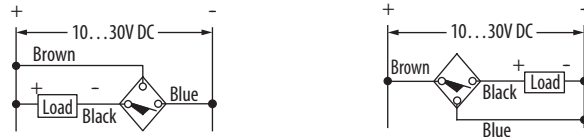

Thread Size	Shielded	mm (in.)			
		A	B (Max)	C (Min)	D (Max)
M12 X 1	Yes	12.0 (0.47)	80.0 (23.15)	53.8 (2.12)	0.8 (0.03)
	No			46.5 (1.83)	8.1 (0.32)
M18 X 1	Yes	18.0 (0.71)	81.5 (3.21)	55.6 (2.19)	0.8 (0.03)
	No			43.7 (1.72)	12.3 (0.48)

Mini QD Style

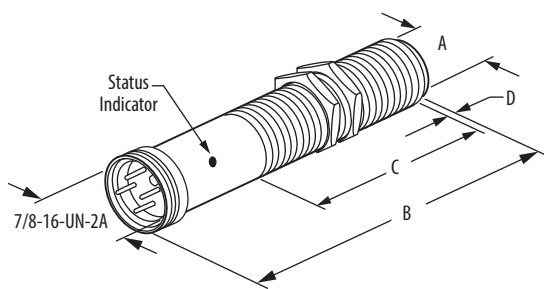

Normally Open

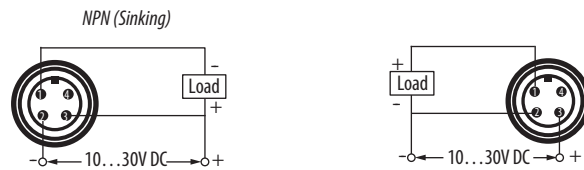

Thread Size	Shielded	mm (in.)			
		A	B (Max)	C (Min)	D (Max)
M18 X 1	Yes	18.0 (0.71)	96.9 (3.81)	51.9 (2.04)	0.8 (0.03)
	No			40.4 (1.59)	12.3 (0.48)

871T 2-wire AC Stainless Steel Barrel Tubular Sensors

Plastic Face/Threaded



871T AC Cable Style
12 mm and 18 mm



871T AC Mini Quick Disconnect Style
18 mm

Specifications

Attribute	12 mm	18 mm
Load Current	≤300 mA	≤500 mA
Inrush Current (one cycle)	≤3 A	≤5 A
Leakage Current	≤1.5 mA	
Operating Voltage	20...132V AC	
Voltage Drop	6.5V AC at 500 mA, 10V AC at 20 mA (RMS)	
Repeatability	≤10%	
Hysteresis	≤10% typical	
Protection Type	False pulse, transient noise	
Certifications	UL Listed, CSA Certified, and CE Marked for all applicable directives	
Enclosure Type Rating	NEMA 1, 2, 3, 4, 12 and 13; IP67 (IEC529)	
Housing Material	Stainless steel 303 barrel	
Connection Type	<ul style="list-style-type: none"> Cable: 3 m (10 ft) length, 12 mm 2 conductor PVC, 18 mm 3 conductor PVC Quick-disconnect: 3-pin mini style 	
Status Indicator	Red: Output Energized	
Operating Temperature	-40...+70 °C (-40...+158 °F)	
Shock	30 g (1.06 oz), 11 ms	
Vibration	55 Hz, 1 mm amplitude, 3 planes	

Correction Factors

Target Material	Correction Factors
Steel	1.0
Stainless Steel	0.7...0.9
Brass	0.3...0.5
Aluminum	0.3...0.4
Copper	0.3...0.4

Approximate Dimensions [mm (in.)]

Cable Style

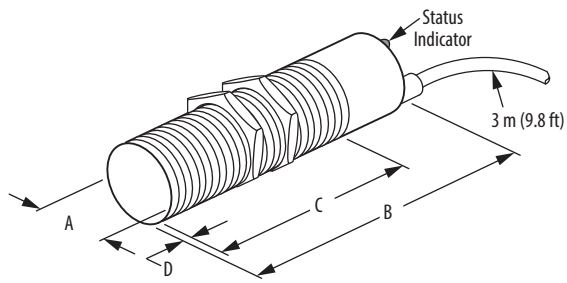

Wiring Diagrams

Normally Open

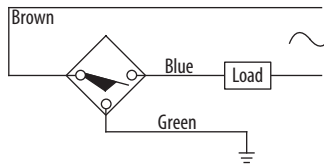

Normally Closed

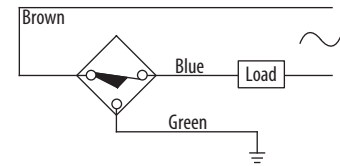

Note: No green wire on 12 mm.
Attach housing to ground.

Thread Size	Shielded	mm (in.)			
		A	B (Max)	C (Min)	D (Max)
M12 X 1	Yes	12.0 (0.47)	80.0 (23.15)	53.8 (2.12)	0.8 (0.03)
	No			46.5 (1.83)	8.1 (0.32)
M18 X 1	Yes	18.0 (0.71)	81.5 (3.21)	55.6 (2.19)	0.8 (0.03)
	No			43.7 (1.72)	12.3 (0.48)

Mini QD Style

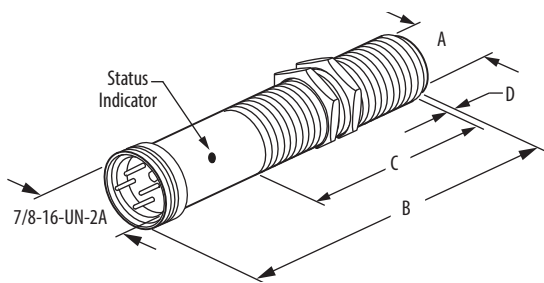

Normally Open or Normally Closed

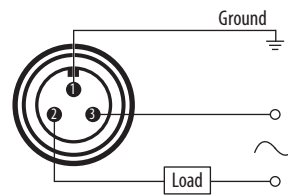

Note: Load can be switched to pin 3.

Thread Size	Shielded	mm (in.)			
		A	B (Max)	C (Min)	D (Max)
M18 X 1	Yes	18.0 (0.71)	96.9 (3.81)	51.9 (2.04)	0.8 (0.03)
	No			40.4 (1.59)	12.3 (0.48)

871T 4-wire AC Ferrous Selective

Stainless Steel Face/Threaded Stainless Steel Barrel



871T AC Cable Style
18 mm



871T AC Mini Quick-disconnect Style
18 mm

Specifications

Attribute	18 mm
Load Current	≤500 mA
Inrush Current (one Cycle)	≤5 A
Supply Current (minimum)	5 mA
Leakage Current	≤1.7 mA
Operating Voltage	20...132V AC
Voltage Drop	<ul style="list-style-type: none"> N.O. output: 6.5V AC at 500 mA, 10V AC at 20 mA (RMS) N.C. output: 1.7V AC at 500 mA (RMS)
Isolation Voltage	800V AC (output to output); 1500V AC (output to housing)
Repeatability	≤10%
Hysteresis	≤10% typical
Protection Type	False pulse, transient noise
Certifications	CE Marked for all applicable directives
Enclosure Type Rating	NEMA 3, 4, 12 and 13; IP67 (IEC529)
Housing Material	Stainless steel face and barrel
Connections	<ul style="list-style-type: none"> Cable: 3.6 m (12 ft) length, 5-conductor PVC Quick-disconnect: 5-pin mini style
Status Indicator	<ul style="list-style-type: none"> Red: Output energized Green: Power
Operating Temperature	0...70 °C (32...158 °F)

Correction Factors

Target Material	Correction Factors
Steel	1.0
Stainless Steel ⁽¹⁾	0.8...1.1
Brass	0.0
Aluminum	0.0
Copper	0.0

(1) Stainless steel 10% contains carbon.

Approximate Dimensions [mm (in.)]

Cable Style

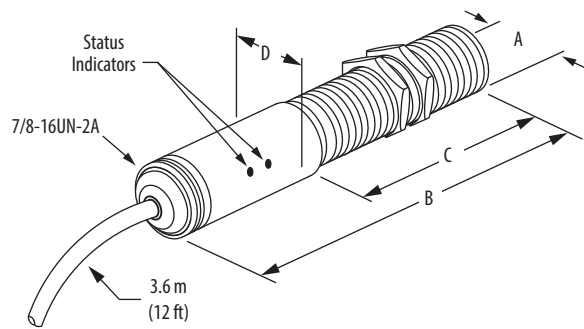

Wiring Diagrams

Complementary Normally Open or Normally Closed

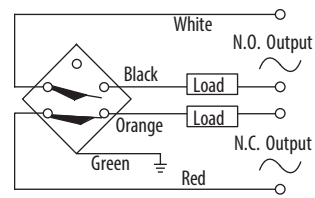

Note:

1. N.O. output must be wired for operation. N.C. output is optional.
2. N.O. load can be switched to white wire.
3. N.C. load can be switched to red wire.

Thread Size	mm (in.)			
	A	B (Max)	C (Min)	D (Max)
M18 X 1	18.0 (0.71)	101.6 (4.00)	50.8 (2.00)	20.3 (0.80)

Mini QD Style

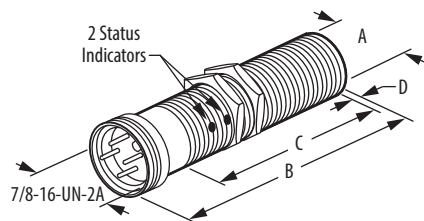

Normally Open or Normally Closed

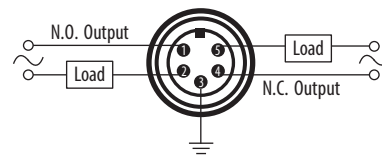

Note:

1. N.O. output must be wired for operation. N.C. output is optional.
2. N.O. load can be switched to pin 1.
3. N.C. load can be switched to pin 4.

Thread Size	mm (in.)			
	A	B (Max)	C (Min)	D (Max)
M18 X 1	18.0 (0.71)	101.6 (4.00)	50.8 (2.00)	20.3 (0.80)

871TM 3-wire DC Short Barrel Tubular Sensors

Stainless Steel Face/Threaded Stainless Steel Barrel



871TM DC Cable Style
12 mm, 18 mm, and 30 mm



871TM DC Mini Quick Disconnect Style
12 mm, 18 mm, and 30 mm



871TM DC Micro Quick Disconnect Style
12 mm, 18 mm, and 30 mm

Specifications

Attribute	12 mm, 18 mm, and 30 mm
Load Current	≤200 mA
Capacitive Load	≤1 μF
Leakage Current	≤10 μA
Operating Voltage	10...30V DC
Voltage Drop	≤1V DC at 200 mA
Repeatability	≤10% at constant temperature
Hysteresis	10% typical
Protection Type	False pulse, transient noise, reverse polarity, short circuit (trigger at 340 mA typical), overload
Certifications	UL Listed, CSA Certified, and CE Marked for all applicable directives
Enclosure Type Rating	NEMA 1, 2, 3, 3R, 4, 4X, 6, 6P, 12, 13 IP67 (IEC529) all models; 1200 psi (8270 kPa) washdown; ToughLink™ and micro connector versions are also rated IP69K (IEC 529)
Housing Material	Stainless steel face and barrel
Connection Type	<ul style="list-style-type: none"> Cable: 2 m (6.5 ft) length, A2 - 3-conductor PVC, C2 - 3-conductor #22 AWG-ToughLink, H2 - 3-conductor #18 AWG ToughLink Quick-disconnect: 4-pin mini style, 4-pin micro style
Indicator Status Indicators	<ul style="list-style-type: none"> Red: Output Energized Green: Power/Short Circuit (flashing)—18 mm models only
Operating Temperature	-25...+70 °C (-13...+158 °F)
Shock	30 g (1.06 oz), 11 ms
Vibration	55 Hz, 1 mm amplitude, 3 planes

Correction Factors

Target Material	Correction Factors
Steel	1.0
Stainless Steel	0.9...1.0
Brass	0.3...0.5
Aluminum	0.1...0.4
Aluminum (≤0.02 Thick)	0.9...1.1
Copper	0.1...0.2

Approximate Dimensions [mm (in.)]

Cable Style

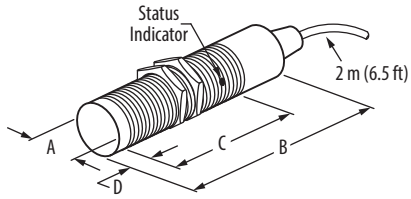

Wiring Diagrams

Normally Open

Normally Closed

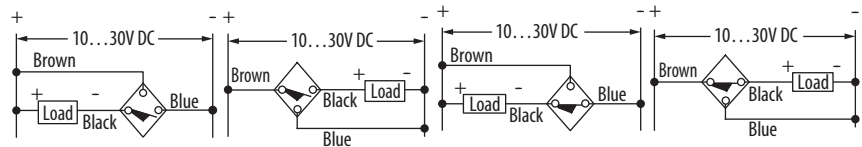

Thread Size	Shielded	mm (in.)			
		A	B	C	D
M12 X 1	Yes	12.0 (0.47)	49.8 (1.96)	26.4 (1.04)	2.5 (0.10)
	No			19.5 (0.77)	9.4 (0.37)
M18 X 1	Yes	18.0 (0.71)	55.4 (2.18)	41.7 (1.64)	2.5 (0.10)
	No			14.5 (0.57)	14.5 (0.57)
M30 X 1.5	Yes	30.0 (1.18)	57.9 (2.28)	41.9 (1.65)	2.5 (0.10)
	No			39.4 (1.55)	18.0 (0.71)

Mini QD Style

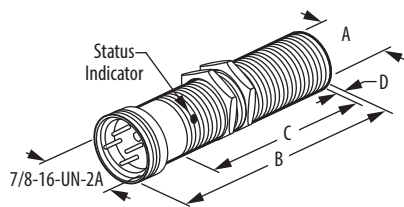

Normally Open

Normally Closed

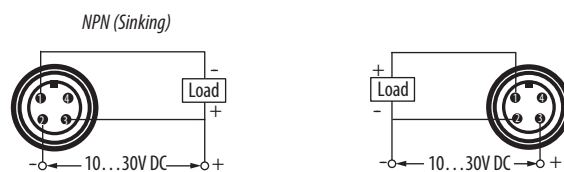

Thread Size	Shielded	mm (in.)			
		A	B	C	D
M12 X 1	Yes	12.0 (0.47)	63.5 (2.50)	25.4 (1.00)	2.5 (0.10)
	No			18.5 (0.73)	9.4 (0.37)
M18 X 1	Yes	18.0 (0.71)	56.1 (2.21)	35.1 (1.38)	2.5 (0.10)
	No			29.2 (1.15)	14.5 (0.57)
M30 X 1.5	Yes	30.0 (1.18)	68.1 (2.68)	41.9 (1.65)	2.5 (0.10)
	No			39.4 (1.55)	18.0 (0.71)

Mini QD Style

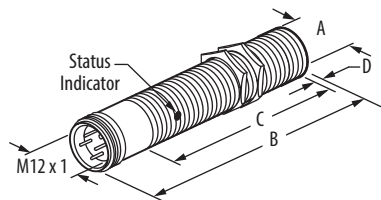

Normally Open or Normally Closed

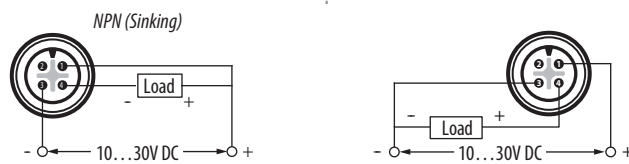

Thread Size	Shielded	mm (in.)			
		A	B	C	D
M12 X 1	Yes	12.0 (0.47)	61.5 (2.40)	26.4 (1.04)	2.5 (0.10)
	No			28.0 (1.10)	9.4 (0.37)
M18 X 1	Yes	18.0 (0.71)	65.1 (2.56)	41.7 (1.64)	2.5 (0.10)
	No			14.5 (0.57)	14.5 (0.57)
M30 X 1.5	Yes	30.0 (1.18)	66.3 (2.61)	41.9 (1.65)	2.5 (0.10)
	No			39.4 (1.55)	18.0 (0.71)

871TM 3-wire DC Weld-field Immune Tubular Sensors

Stainless Steel Face/Threaded Stainless Steel Barrel



871TM DC Pico Quick-disconnection Style
8 mm



871TM DC Micro Quick Disconnect Style
12 mm



871TM DC Micro
18 mm

Specifications

Attribute	8 mm, 12 mm, and 18 mm
Load Current	≤ 200 mA
Leakage Current	≤ 0.1 mA
Operating Voltage	10...30V DC
Voltage Drop	≤ 2V DC at 200 mA
Repeatability	≤ 5% at constant temperature, maximum sensing range
Hysteresis	15% typical
Protection Type	False pulse, transient noise, reverse polarity, short circuit (trigger at 340 mA typical), overload
Certifications	c-UL-us Listed and CE Marked for all applicable directives
Enclosure Type Rating	8/12/18 mm: IP68/IP69K
Housing Material	Stainless steel face and barrel, resistant to weld splatter
Connection Type	Quick-disconnect: 4-pin micro style, 3-pin pico style
Indicator Status Indicators	Yellow: Output energized/360° visibility flashing status indicator indicates target that is located between 80...100% of rated sensing distance
Operating Temperature	-25...+85 °C (-13...+185 °F)
Shock	30 g (1.06 oz), 11 ms
Vibration	55 Hz, 1 mm amplitude, 3 planes
Weld-Field Immunity	≤ 40 mT

Correction Factors

Target Material	Barrel Size and Sensing Range		
	M8	M12	M18
	3 mm	6 mm	10 mm
Steel			1.00
Copper ¹	1.00	0.85	1.15
Aluminum	1.00	1.00	1.40
Brass	1.30	1.30	1.50
Stainless Steel ¹ 1 mm/2 mm	0.4/0.70	0.5/0.90	0.1/0.6

Approximate Dimensions [mm (in.)]

Micro QD Style

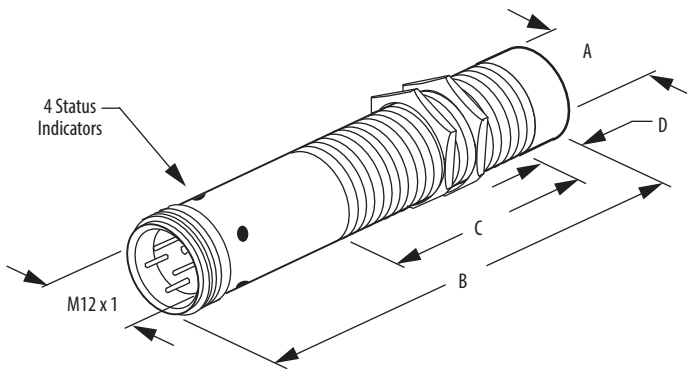

Wiring Diagrams

Normally Open

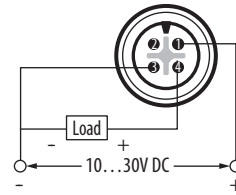

Thread Size	Shielded	mm (in.)			
		A	B	C	D
M12 X 1	Yes	12.0 (0.47)	60 (2.36)	41 (1.61)	—
M18 X 1	Yes	18.0 (0.71)	63.5 (2.5)	42.5 (1.67)	—

Micro QD Style

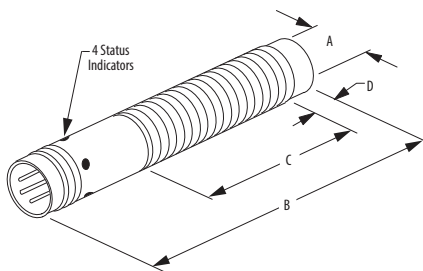

Normally Open

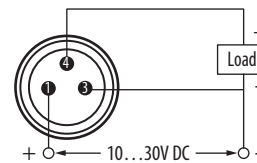

Thread Size	Shielded	mm (in.)			
		A	B	C	D
M8 X 1	Yes	8.0 (0.31)	60 (2.35)	45.5 (1.79)	—

871TM 3-wire DC Long-range Sensing Tubular Sensors

Stainless Steel Face/Threaded Stainless Steel Barrel



871TM Pico Quick-disconnection Style
8 mm



871TM DC Micro Quick-disconnect Style
12 mm



871TM DC Cable Style
18 mm



871TM DC Micro Quick-disconnect Style
30 mm

Specifications

Attribute	8 mm, 12 mm, 18 mm, and 30 mm
Load Current	≤ 200 mA
Capacitive Load	≤ 1 mF
Leakage Current	≤ 0.1 mA
Operating Voltage	10...30V DC
Voltage Drop	≤ 2V DC at 200 mA
Repeatability	≤ 5% at constant temperature
Hysteresis	10% typical
Protection Type	False pulse, transient noise, reverse polarity, short circuit (trigger at 340 mA typical), overload
Certifications	c-UL-us Listed and CE Marked for all applicable directives
Enclosure Type Rating	<ul style="list-style-type: none"> 12/18/30 mm: IP68/IP69K 8 mm quick-disconnect models: IP67 8 mm cable models: IP68
Housing Material	Stainless steel face and barrel
Connection Type	<ul style="list-style-type: none"> Cable: 2 m (6.5 ft) length Quick-disconnect: 4-pin micro style, 3-pin pico style
Status Indicators	Yellow: Output energized/360° status indicator visibility, flashing status indicator indicates target that is located between 80...100% of rated sensing distance
Operating Temperature	-25...+70 °C (-13...+158 °F)
Shock	30 g (1.06 oz), 11 ms
Vibration	55 Hz, 1 mm amplitude, 3 planes
IO-Link (enabled on normally open, PNP models only)	
Protocol	IO-Link V1.0
Interface-type	IO-Link
Mode	COM2 (38.4 kBd)
Cycle Time	8 ms minimum
SIO (Standard I/O)	Supported (pin 4 for either IO-Link or SIO)

Switching Frequency

Barrel Diameter [mm]	Switching Frequency [Hz]
8	700
12	400
18	200
30	80

Correction Factors

Instructions for unshielded sensor:

1. To determine the appropriate correction factor, only use [Table 1](#).
2. To determine derated sensing distance (if applicable), multiply the sensor type with the target material by the sensing range.

Instructions for shielded sensor:

1. To determine the appropriate correction factor, use [Table 1](#) and [Table 2](#).
2. In [Table 1](#), determine the appropriate correction factor based on the type and the target material.
3. In [Table 2](#), multiply the result from [Table 1](#) by the material the sensor is mounted in. The result is the final correction factor.

Table 1 - Sensor Type and Target Material Correction Factor

Sensor Type/ Target Material (No Surrounding Metal)	8 mm Diameter		12 mm Diameter		18 mm Diameter		30 mm Diameter	
	Unshielded	Shielded	Unshielded	Shielded	Unshielded	Shielded	Unshielded	Shielded
Steel	1	1	1	1	1	1	1	1
Copper	0.90	0.85	0.85	0.80	0.80	0.90	0.90	0.90
Aluminum	1	1	1	1	1	1	1	1
Brass	1.35	1.4	1.3	1.4	1.2	1.35	1.3	1.2
Stainless Steel	0.3/0.6	0.3/0.9	0.5/0.9	NA/0.65	0.5/0.9	0.2/0.7	0.35/0.7	NA/0.25

Table 2 - Surrounding Material

Surrounding Material Type	8 mm Dia.	12 mm Dia.	18 mm Dia.	30 mm Dia.
	Shielded			
Steel	1	0.7	0.75	0.9
Aluminum	0.9	1.15	0.9	0.7
Brass	0.9	1.05	0.75	0.6
Stainless Steel	1	0.8	0.8	1.3

The following table indicates the protrusion distance from the mounting device for the unshielded sensor face.

Surrounding Material Type	8 mm Dia.	12 mm Dia.	18 mm Dia.	30 mm Dia.
	Unshielded			
Steel	15 mm	22 mm	36 mm	18 mm
Aluminum	9 mm	13 mm	22 mm	34 mm
Brass	10 mm	15 mm	22 mm	34 mm
Stainless Steel	14 mm	21 mm	43 mm	18 mm

Approximate Dimensions [mm (in.)]

Cable Style

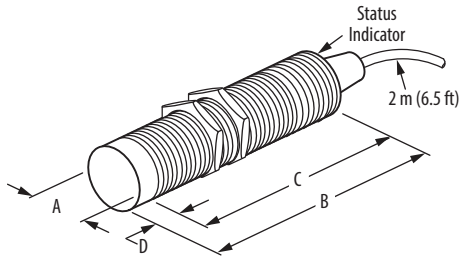

Wiring Diagrams

Normally Open

Normally Closed

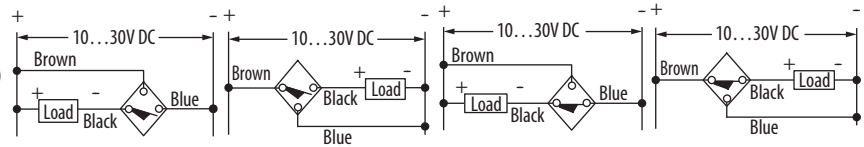

Thread Size	Shielded	mm (in.)			
		A	B	C	D
M8 X 1	Yes	8.0 (0.31)	45 (1.76)	45 (1.76)	—
	No			41 (1.61)	4 (0.16)
M12 X 1	Yes	12.0 (0.47)	61.5 (2.40)	50 (1.96)	—
	No			45 (1.77)	5 (0.19)
M18 X 1	Yes	18.0 (0.71)	65.1 (2.56)	50 (1.96)	—
	No			43 (1.69)	7.0 (0.27)
M30 X 1.5	Yes	30.0 (1.18)	66.3 (2.61)	50.0 (1.96)	—
	No			40.0 (1.57)	10.0 (0.39)

Micro Style

Normally Open

Normally Closed

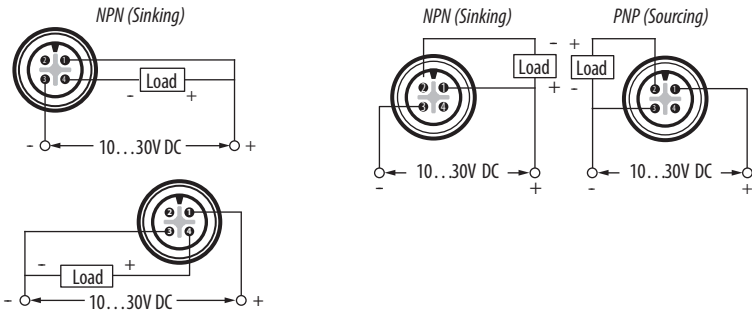
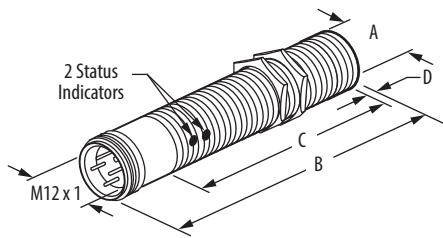

Thread Size	Shielded	mm (in.)			
		A	B	C	D
M8 X 1	Yes	8.0 (0.31)	66 (2.59)	46 (1.81)	—
	No			42 (1.65)	4 (0.16)
M12 X 1	Yes	12.0 (0.47)	60 (2.26)	41 (1.61)	—
	No			36 (1.42)	5 (0.19)
M18 X 1	Yes	18.0 (0.71)	63.5 (2.5)	42.5 (1.67)	—
	No			35.5 (1.40)	7.0 (0.27)
M30 X 1.5	Yes	30.0 (1.18)	66.3 (2.61)	42.5 (1.67)	—
	No			32.5 (1.28)	10.0 (0.39)

Approximate Dimensions [mm (in.)]

Pico Style

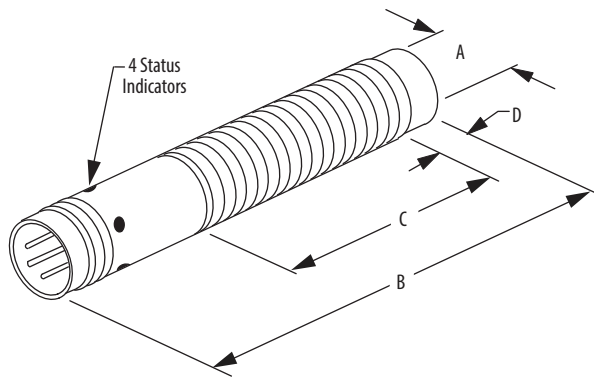

Wiring Diagrams

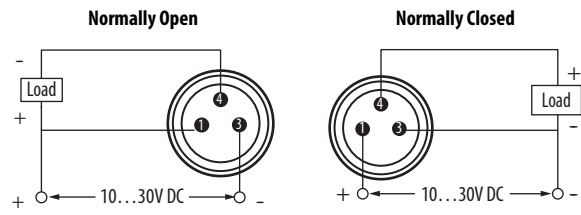

Thread Size	Shielded	mm (in.)			
		A	B (max.)	C (min.)	D (max.)
M8 X 1	Yes	8.0 (0.31)	66 (2.59)	46 (1.81)	—
	No			42 (1.65)	4 (0.16)

871TM 3-wire DC Ferrous or Nonferrous Selective Tubular Sensors

Stainless Steel Face/Threaded Stainless Steel Barrel



871TM DC Micro Quick-disconnection Style
12 mm, 18 mm, and 30 mm



871TM DC ToughLink Cable Style
12 mm, 18 mm, and 30 mm



871TM DC Mini Quick-disconnect Style
12 mm, 18 mm, and 30 mm



871TM DC Micro Cable Style
12 mm, 18 mm, and 30 mm

Specifications

Attribute	12 mm, 18 mm, and 30 mm
Load Current	≤200 mA
Capacitive Load	≤1 μF
Leakage Current	≤10 μA
Operating Voltage	10...30V DC
Voltage Drop	≤1V DC at 200 mA
Repeatability	≤10% at constant temperature
Hysteresis	10% typical
Protection Type	False pulse, transient noise, reverse polarity, short circuit (trigger at 340 mA typical), overload
Certifications	UL Listed, CSA Certified, and CE Marked for all applicable directives
Enclosure Type Rating	NEMA 1, 2, 3, 3R, 4, 4X, 6, 6P, 12, 13; IP67 (IEC529) all models; 1200 psi (8270 kPa) washdown; ToughLink and micro connector versions are also rated IP69K (IEC 529)
Housing Material	Stainless steel face and barrel
Connection Type	<ul style="list-style-type: none"> Cable: 2 m (6.5 ft) length, A2 - 3-conductor PVC, C2 3-conductor #22 AWG ToughLink, H2 - 3-conductor #18 AWG ToughLink; Quick-disconnect: 4-pin mini style, 4-pin micro style
Indicator Status Indicators	<ul style="list-style-type: none"> Red: Output energized Green: Power/short circuit (flashing)—18 mm models only
Operating Temperature	-25...+70 °C (-13...+158 °F)
Shock	30 g (1.05 oz), 11 ms
Vibration	55 Hz, 1 mm amplitude, 3 planes

Correction Factors

Target Material	Ferrous Selective	Nonferrous Selective
Steel	1.0	0.0
Stainless Steel	0...1.0 ⁽¹⁾	0...1.0 ⁽¹⁾
Brass	0.0	1.0
Aluminum	0.0	1.0
Aluminum (>0.003 thick)	0.0	1.0
Copper	0.0	1.0

(1) Variations due to differences in alloy composition.

Approximate Dimensions [mm (in.)]

Cable Style

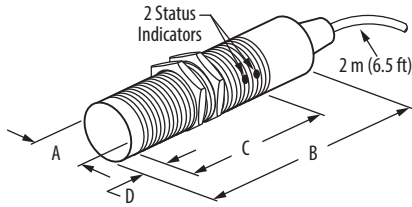

Status Indicators available on 18 mm models only

Wiring Diagrams

Normally Open

Normally Closed

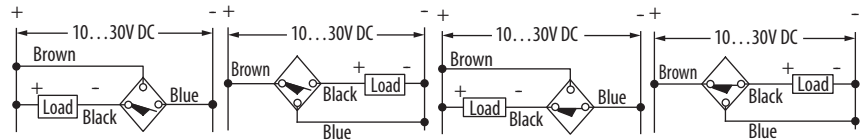

Thread Size	Shielded	Target Type	mm (in.)			
			A	B	C	D
M12 X 1	Yes	Ferrous	12.0 (0.47)	51.0 (2.01)	27.5 (1.08)	—
M18 X 1		Ferrous	18.0 (0.71)	76.8 (3.02)	65.0 (2.56)	—
		Nonferrous	18.0 (0.71)	74.7 (2.94)	60.0 (2.36)	2.5 (0.10)
M30 X 1.5		Nonferrous	30.0 (1.18)	77.5 (3.05)	63.0 (2.48)	2.5 (0.10)

Mini QD Style

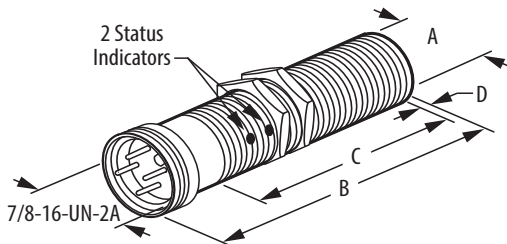

Status Indicators available on 18 mm models only

Normally Open

Normally Closed

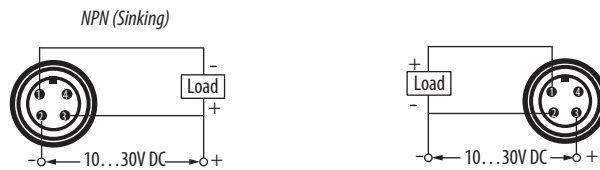

Thread Size	Shielded	Target Type	mm (in.)			
			A	B	C	D
M12 X 1	Yes	Ferrous	12.0 (0.47)	61.3 (2.45)	30.4 (1.20)	—
M18 X 1		Ferrous	18.0 (0.71)	78.5 (3.14)	60.0 (2.36)	—
		Nonferrous	18.0 (0.71)	76.6 (3.02)	54.9 (2.16)	2.5 (0.10)
M30 X 1.5		Nonferrous	30.0 (1.18)	86.0 (3.39)	63.5 (2.50)	2.5 (0.10)

Micro QD Style

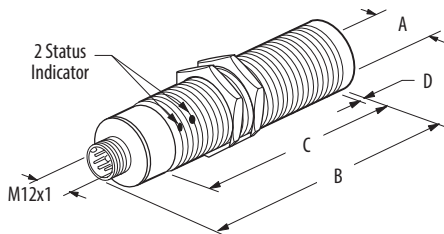

Status Indicators available on 18 mm models only

Normally Open or Normally Closed



Thread Size	Shielded	Target Type	mm (in.)			
			A	B	C	D
M12 X 1	Yes	Ferrous	12.0 (0.47)	62.3 (2.45)	30.4 (1.20)	0.9 (0.04)
M18 X 1		Ferrous	18.0 (0.71)	85.0 (3.35)	65.5 (2.58)	2.0 (0.08)
		Nonferrous	18.0 (0.71)	84.3 (3.32)	60.0 (2.36)	2.5 (0.10)
M30 X 1.5		Nonferrous	30.0 (1.18)	85.5 (3.37)	63.0 (2.48)	2.5 (0.10)

871TM 2-wire DC Short Barrel Tubular Sensors

Stainless Steel Face/Threaded Stainless Steel Barrel



871TM DC Cable Style
12 mm, 18 mm, and 30 mm



871TM DC Mini Quick-disconnect Style
12 mm, 18 mm, and 30 mm



871TM DC Micro
12 mm, 18 mm, and 30 mm

Specifications

Attribute	12 mm, 18 mm, and 30 mm
Load Current	≤25 mA
Load Current, Minimum	2 mA
Leakage Current	≤0.9 mA
Operating Voltage	10...30V DC
Voltage Drop	≤8V
Repeatability	10% typical
Hysteresis	10% typical
Protection Type	False pulse, transient noise, reverse polarity, short circuit, overload
Certifications	UL Listed, CSA Certified, and CE Marked for all applicable directives
Enclosure Type Rating	NEMA 1, 2, 3, 3R, 4, 4X, 6, 6P, 12, 13; IP67 (IEC 529) all models; 1200 psi (8270 kPa) washdown; ToughLink and micro connector versions are also rated IP69K (IEC 529)
Housing Material	Stainless steel face and barrel
Connection Type	<ul style="list-style-type: none"> Cable: 2 m (6.5 ft) length, A2 - 2-conductor PVC, C2 - 2-conductor #22 AWG ToughLink, H2 - 2-conductor #18 AWG ToughLink Quick-disconnect: 4-pin mini style, 4-pin micro style
Indicator Status Indicators	Red: Output Energized
Operating Temperature	-25...+70 °C (-13...+158 °F)
Shock	30 g (1.06 oz), 11 ms
Vibration	55 Hz, 1 mm amplitude, 3 planes

Correction Factors

Target Material	Correction Factors
Steel	1.0
Stainless Steel	0.9...1.0
Brass	0.3...0.5
Aluminum	0.1...0.4
Aluminum (≤0.02 Thick)	0.9...1.1
Copper	0.1...0.2

Approximate Dimensions [mm (in.)]

Cable Style

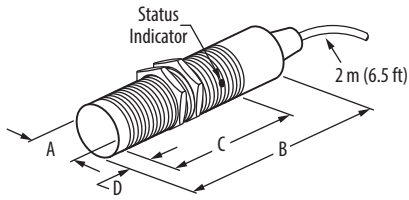

Typical Wiring Diagrams

Normally Open

Normally Closed

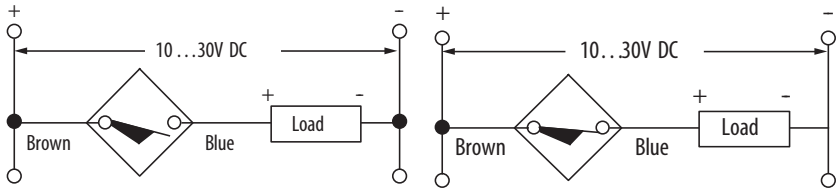

Thread Size	Shielded	mm (in.)			
		A	B	C	D
M12 X 1	Yes	12.0 (0.47)	49.8 (1.96)	26.4 (0.10)	2.5 (0.10)
	No			19.5 (0.77)	9.4 (0.37)
M18 X 1	Yes	18.0 (0.71)	55.4 (2.18)	41.7 (1.64)	2.5 (0.10)
	No			14.5 (0.57)	
M30 X 1.5	Yes	30.0 (1.18)	57.9 (2.28)	41.9 (1.65)	2.5 (0.10)
	No			39.4 (1.55)	18.0 (0.71)

Mini QD Style

Normally Open or Normally Closed

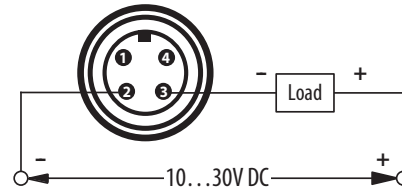
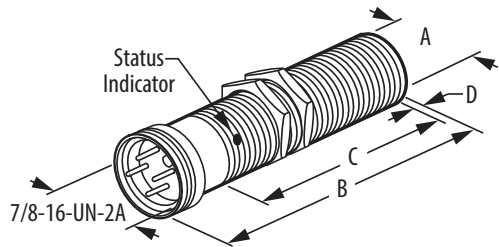

Thread Size	Shielded	mm (in.)			
		A	B	C	D
M12 X 1	Yes	12.0 (0.47)	63.5 (2.50)	25.4 (1.00)	2.5 (0.10)
	No			18.5 (0.73)	9.4 (0.37)
M18 X 1	Yes	18.0 (0.71)	56.1 (2.21)	35.1 (1.38)	2.5 (0.10)
	No			29.2 (1.15)	14.5 (0.57)
M30 X 1.5	Yes	30.0 (1.18)	68.1 (2.68)	49.1 (1.65)	2.5 (0.10)
	No			39.4 (1.55)	18.0 (0.71)

Micro QD Style

Normally Open or Normally Closed

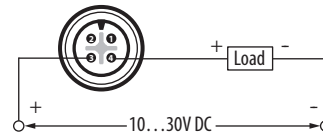
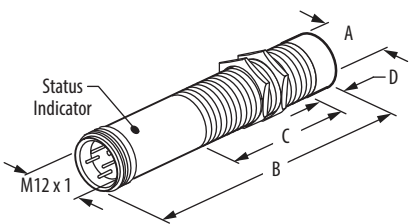

Thread Size	Shielded	mm (in.)			
		A	B	C	D
M12 X 1	Yes	12.0 (0.47)	61.0 (2.40)	26.4 (1.04)	2.5 (0.10)
	No			19.6 (0.77)	9.4 (0.37)
M18 X 1	Yes	18.0 (0.71)	65.0 (2.56)	41.7 (1.64)	2.5 (0.10)
	No			14.5 (0.57)	
M30 X 1.5	Yes	30.0 (1.18)	66.3 (2.61)	41.9 (1.65)	2.5 (0.10)
	No			39.4 (1.55)	18.0 (0.71)

871TM 2-wire AC/DC All Stainless Steel Tubular Sensors

Stainless Steel Face/Threaded Stainless Steel Barrel



871TM AC/DC Cable Style
12 mm, 18 mm, and 30 mm



871TM AC/DC Mini
Quick-disconnect Style
12 mm, 18 mm, and 30 mm



871TM AC/DC Micro Quick-disconnect Style
12 mm, 18 mm, and 30 mm



871TM AC/DC EAC Micro
Quick-disconnect Style
12 mm



871TM AC/DC
ToughLink Cable Style
12 mm, 18 mm, and 20 mm

Specifications

Attribute	12 mm	18 mm and 30 mm
Load Current	5...200 mA	5...250 mA
Inrush Current (one cycle)	≤2 A	≤4 A
Leakage Current	≤1.9 mA @ 120V AC	
Operating Voltage	20...250V AC/DC	
Voltage Drop	≤10V @ 5...200 mA	≤10V @ 5...250 mA
Repeatability	≤10% at constant temperature	
Hysteresis	7% typical	
Protection Type	False pulse, transient noise, short circuit (trigger @ 5 A typical), and overload (trigger @ 260 mA typical)	False pulse, transient noise, short circuit (trigger @ 8 A typical), and overload (trigger @ 320 mA typical)
Certifications	UL Listed, CSA Certified, and CE Marked for all applicable directives, CCC Certified (select models)	
Enclosure Type Rating	NEMA 1, 2, 3, 3R, 4, 4X, 6, 6P, 12, 13; IP67 (IEC 529) all models; 1200 psi (8270 kPa) washdown; ToughLink and micro connector versions are also rated IP69K (IEC 529)	
Housing Material	Stainless steel face and barrel	
Connection Type	<ul style="list-style-type: none"> Cable: 2 m (6.5 ft) length; A2—2-conductor #22 AWG PVC, C2—2-conductor #22 AWG ToughLink, H2—3-conductor #18 AWG ToughLink Quick-disconnect: 3-pin mini style, 3-pin micro style, 4-pin EAC micro style 	
Indicator Status Indicators	<ul style="list-style-type: none"> Red: Output energized Green: Power Short circuit: Red and green flashing 	
Operating Temperature	-25...+70 °C (-13...+158 °F)	
Shock	30 g (1.06 oz), 11 ms	
Vibration	55 Hz, 1 mm amplitude, 3 planes	

Correction Factors

Target Material	Correction Factors
Steel	1.0
Stainless Steel	0.9...1.0
Brass	0.3...0.5
Aluminum	0.1...0.4
Aluminum (≤0.02 Thick)	0.9...1.1
Copper	0.1...0.2

Approximate Dimensions [mm (in.)]

EAC Micro QD Style

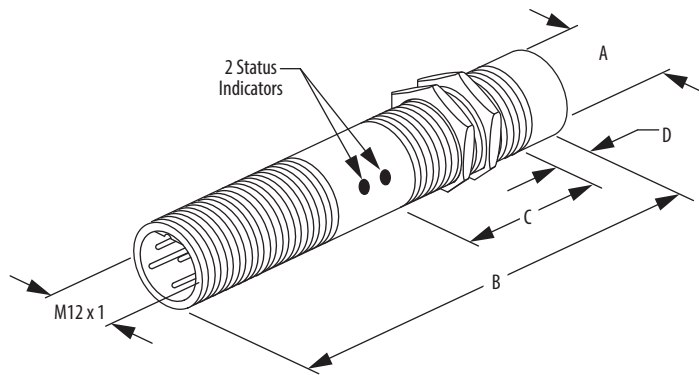

Typical Wiring Diagrams

Normally Open

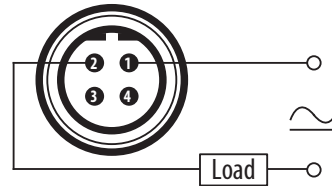

Thread Size	Shielded	mm (in.)			
		A	B	C	D
M12 X 1	No	12.0 (0.47)	83.0 (3.27)	31.7 (1.25)	9.4 (0.37)

Cable Style

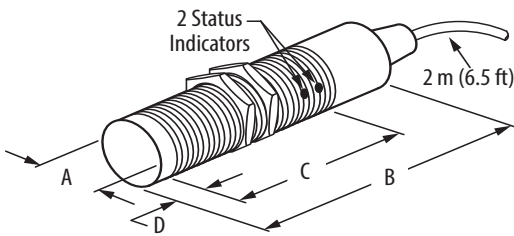

Normally Open

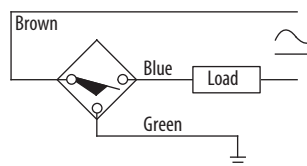

Normally Closed

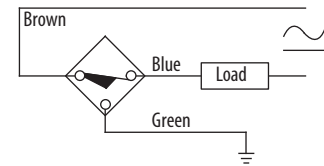

Note: No green wire on 12 mm and on sensors with PVC cable (-A2). Attach housing to ground.
Note: Load can be switched to brown wire.

Thread Size	Shielded	mm (in.)			
		A	B	C	D
M12 X 1	Yes	12.0 (0.47)	72.1 (2.84)	38.4 (1.51)	2.5 (0.10)
	No			31.5 (1.24)	9.4 (0.37)
M18 X 1	Yes	18.0 (0.71)	74.7 (2.94)	60.0 (2.35)	2.5 (0.10)
	No			48.2 (1.90)	14.4 (0.56)
M30 X 1.5	Yes	30.0 (1.18)	77.2 (3.04)	61.3 (2.41)	2.5 (0.10)
	No			46.1 (1.81)	17.9 (0.70)

Approximate Dimensions [mm (in.)]

Mini QD Style

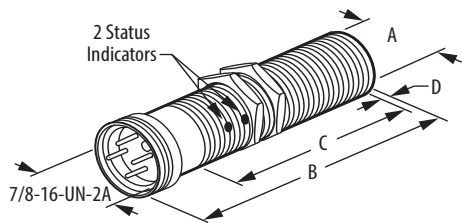

Typical Wiring Diagrams

Normally Open or Normally Closed

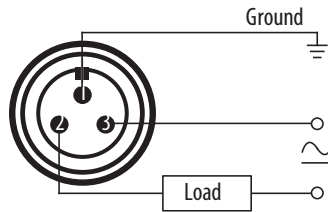

Note: No ground pin on 12 mm. Attach housing to ground.
Note: Load can be switched to pin3

Thread Size	Shielded	mm (in.)			
		A	B	C	D
M12 X 1	Yes	12.0 (0.47)	85.6 (3.37)	37.8 (1.49)	2.5 (0.10)
	No			31.7 (1.25)	9.4 (0.37)
M18 X 1	Yes	18.0 (0.71)	56.1 (2.21)	54.9 (2.16)	2.5 (0.10)
	No			43.1 (1.70)	14.4 (0.56)
M30 X 1.5	Yes	30.0 (1.18)	68.1 (2.68)	61.3 (2.41)	2.5 (0.10)
	No			46.1 (1.81)	17.9 (0.70)

Micro QD Style

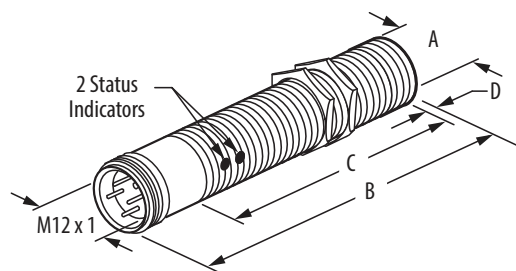

Normally Open or Normally Closed

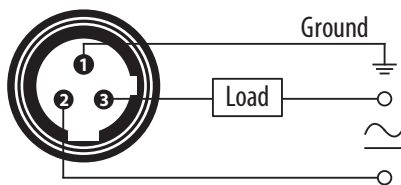

Note: No ground pin on 12 mm. Attach housing to ground.
Note: Load can be switched to pin3

Thread Size	Shielded	mm (in.)			
		A	B	C	D
M12 X 1	Yes	12.0 (0.47)	83.4 (3.28)	38.4 (1.51)	2.5 (0.10)
	No			31.5 (1.24)	9.4 (0.37)
M18 X 1	Yes	18.0 (0.71)	84.3 (3.32)	60.0 (2.36)	2.5 (0.10)
	No			48.2 (1.90)	14.4 (0.56)
M30 X 1.5	Yes	30.0 (1.18)	85.7 (3.37)	61.3 (2.41)	2.5 (0.10)
	No			46.1 (1.81)	17.9 (0.70)

871TM 2-wire AC/DC PLC Interfacer

Stainless Steel Face/Threaded Short Stainless Steel Barrel



Specifications

Attribute	12 mm, 18 mm, and 30 mm
Load Current	2...25 mA
Leakage Current	≤0.9 mA at 24V DC ≤1.7 mA at 20...120V AC/DC ≤2.5 mA at 121...250V AC/DC
Operating Voltage	20...250V AC/DC (standard models) 20...132V AC/DC (high temperature models)
Voltage Drop	≤8V at 25 mA DC ≤10V at 25 mA AC
Repeatability	10% typical
Hysteresis	10% typical
Protection Type	False pulse, transient noise, radio frequency (10V per meter, frequency range 20...1000 MHz) ⁽¹⁾
Certifications	UL Listed, CSA Certified, and CE Marked for all applicable directives CCC Certified (select models)
Enclosure Type Rating	NEMA 1, 2, 3, 3R, 4, 4X, 6, 6P, 12, 13; IP67 (IEC 529) all models; 1200 psi (8270 kPa) washdown; ToughLink and micro connector versions are also rated IP69K (IEC 529)
Housing Material	Stainless steel face and barrel
Connection Type	<ul style="list-style-type: none"> Cable: 2 m (6.5 ft) length, A2 - 2-conductor #22 AWG PVC, C2 - 2-conductor #22 AWG ToughLink, H2 - 2-conductor #18 AWG ToughLink Quick-disconnect: 3-pin mini style, 3-pin micro style, 4-pin EAC micro style
Indicator Status Indicators	Red: Output Energized
Operating Temperature	-25...+70 °C (-13...+158 °F) (standard models) 0...100 ° (32...212 °) (high temperature models)
Shock	30 g (1.06 oz), 11 ms (standard models) 5 g (0.18 oz), 11 ms (high temperature models)
Vibration	55 Hz, 1 mm amplitude, 3 planes (standard models) 30...120 Hz, 1 mm amplitude, 3 planes (high temperature models)

Correction Factors

Target Material	Correction Factors
Steel	1.0
Stainless Steel	0.8...1.0
Brass	0.4...0.7
Aluminum	0.4...0.7
Copper	0.1...0.2

(1) Radio frequency protection is not available on high temperature models.

Approximate Dimensions [mm (in.)]

EAC Micro QD Style

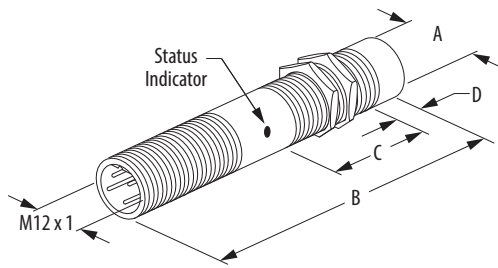

Typical Wiring Diagrams

Normally Open

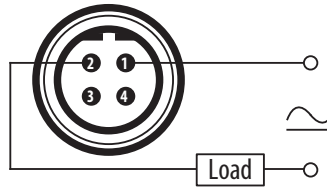

Note: No ground pin. Attach housing to ground.
Note: Load can be switched to pin 2.

Thread Size	Shielded	mm (in.)			
		A	B	C	D
M12 X 1	No	12.0 (0.47)	61.0 (2.40)	26.4 (1.04)	2.5 (0.10)

Cable Style

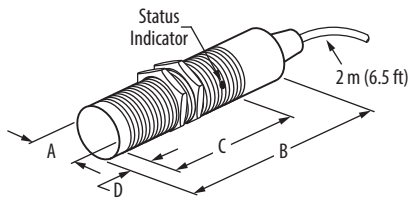

Normally Open

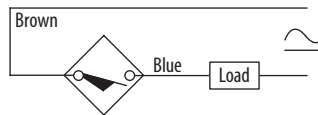

Note: Attach housing to ground.
Note: Load can be switched to brown wire.

Thread Size	Shielded	mm (in.)			
		A	B	C	D
M12 X 1	Yes	12.0 (0.47)	49.8 (1.96)	26.4 (1.04)	2.5 (0.10)
	No			19.5 (0.77)	9.4 (0.37)
M18 X 1	Yes	18.0 (0.71)	55.4 (2.18)	41.7 (1.64)	2.5 (0.10)
	No				14.5 (0.57)
M30 X 1.5	Yes	30.0 (1.18)	57.9 (2.28)	41.9 (1.65)	2.5 (0.10)
	No			39.4 (1.55)	18.0 (0.71)

Approximate Dimensions [mm (in.)]

Mini QD Style

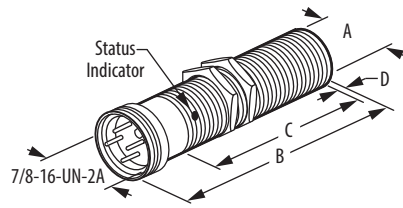

Typical Wiring Diagrams

Normally Open

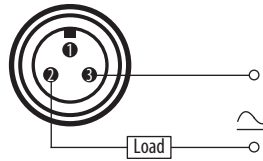

Note: Attach housing to ground.
Note: Load can be switched to pin3.

Thread Size	Shielded	mm (in.)			
		A	B	C	D
M12 X 1	Yes	12.0 (0.47)	63.5 (2.50)	25.4 (1.00)	2.5 (0.10)
	No			18.5 (0.73)	9.4 (0.37)
M18 X 1	Yes	18.0 (0.71)	56.1 (2.21)	35.1 (1.38)	2.5 (0.10)
	No			29.2 (1.15)	14.5 (0.57)
M30 X 1.5	Yes	30.0 (1.18)	68.1 (2.68)	49.1 (1.65)	2.5 (0.10)
	No			39.4 (1.55)	18.0 (0.71)

Micro QD Style

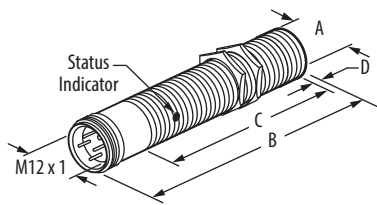

Normally Open or Normally Closed

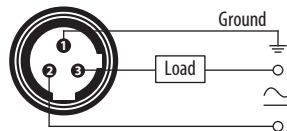

Note: Attach housing to ground.
Note: Load can be switched to pin2.

Thread Size	Shielded	mm (in.)			
		A	B	C	D
M12 X 1	Yes	12.0 (0.47)	83.4 (3.28)	26.4 (1.04)	2.5 (0.10)
	No			19.6 (0.77)	9.4 (0.37)
M18 X 1	Yes	18.0 (0.71)	84.3 (3.32)	41.7 (1.64)	2.5 (0.10)
	No				14.5 (0.57)
M30 X 1.5	Yes	30.0 (1.18)	85.7 (3.37)	41.9 (1.65)	2.5 (0.10)
	No			39.4 (1.55)	18.0 (0.71)

871TM 2-wire DC Intrinsically Safe Stainless Steel Face and Barrel



871TM Intrinsically Safe
Cable Style



871TM Intrinsically Safe
Micro Quick-disconnect Style
12 mm, 18 mm, and 30 mm



871TM Intrinsically Safe
ToughLink Cable Style
12 mm

Specifications

Attribute	12 mm, 18 mm, and 30 mm
Outputs	Normally open
Load Current, Max.	25 mA
Load Current, Min.	2 mA
Leakage Current	$t \leq 1.0$ mA
Operating Voltage	10...31.5V DC
Voltage Drop	≤ 8 V DC
Repeatability	10% typical
Hysteresis	10% typical
Protection Type	False pulse, transient noise, reverse polarity, short circuit, overload
Certifications	FM Approved and CSA Certified for: <ul style="list-style-type: none"> Class I, II, III; Divisions 1, 2; Groups A, B, C, D, E, F, G when used with an approved intrinsic safety barrier Class I, II, III; Division 2; Groups A, B, C, D, E, F, G without intrinsic safety barrier UL Listed for use in non-hazardous locations (See control drawing 75001-437 for approval details and wiring diagrams)
Enclosure Type Rating	NEMA 1, 2, 3, 3R, 4, 4X, 6, 6P, 12, 13; IP67 (IEC 529) all models; 1200 psi (8270 kPa) washdown; stainless steel face and barrel; ToughLink and micro connector versions are also rated IP69K (IEC 529)
Connection Type	<ul style="list-style-type: none"> Cable: 2 m (6.5 ft) length, A2 - 2 conductor #22 AWG PVC, C2 - 2 conductor #22 AWG ToughLink, H2 - 2 conductor #18 AWG ToughLink Quick Disconnect: 4-pin micro style
Indicator Status Indicators	Red: Output energized
Operating Temperature	-25...+70 °C (-13...+158 °F)
Shock	30 g (1.06 oz), 11 ms
Vibration	55 Hz, 1 mm amplitude, 3 planes

Correction Factors	
Target Material	Correction Factor
Steel	1.0
Stainless Steel	0.9...1.0
Brass	0.3...0.5
Aluminum	0.1...0.4
Aluminum (≤ 0.02 Thick)	0.9...1.1
Copper	0.1...0.2

Entity Parameters			
Sensor			Barrier
V_{MAX}	31.5V	\geq	V_t
I_{MAX}	130 mA	\geq	I_t
P_{MAX}	1.25 W	\geq	P_t
C_i	0 μ f	\leq	C_a
L_i	0 mH	\leq	L_{ta}

IMPORTANT Operating parameters must be adhered to.

Approximate Dimensions [mm (in.)]

Cable Style

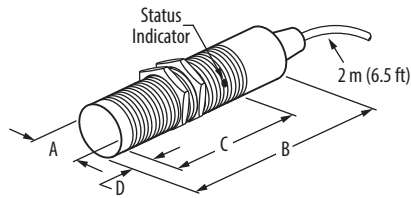

Thread Size	Shielded	mm (in.)			
		A	B	C	D
M12 X 1	Yes	12.0 (0.47)	72.1 (2.84)	36.1 (1.42)	2.5 (0.10)
	No			29.2 (1.15)	9.4 (0.37)
M18 X 1	Yes	18.0 (0.71)	75.7 (2.94)	56.2 (1.22)	2.5 (0.10)
	No			44.5 (1.75)	14.4 (0.56)
M30 X 1.5	Yes	30.0 (1.18)	77.2 (3.04)	58.4 (2.30)	2.5 (0.10)
	No			43.2 (1.70)	17.9 (0.70)

Micro QD Style

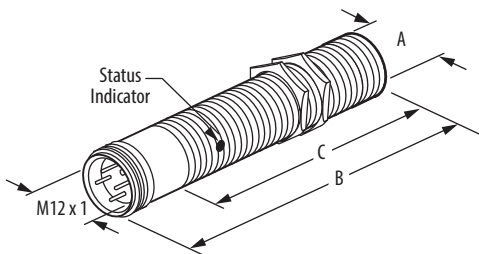

Thread Size	Shielded	mm (in.)			
		A	B	C	D
M12 X 1	Yes	12.0 (0.47)	83.3 (3.28)	36.1 (1.42)	2.5 (0.10)
	No			29.2 (1.15)	9.4 (0.37)
M18 X 1	Yes	18.0 (0.71)	84.3 (3.32)	56.3 (2.22)	2.5 (0.10)
	No			44.5 (1.75)	14.4 (0.56)
M30 X 1.5	Yes	30.0 (1.18)	86.1 (3.39)	58.4 (2.30)	2.5 (0.10)
	No			43.2 (1.70)	17.9 (0.70)

Division 1 Installation Wiring Diagrams

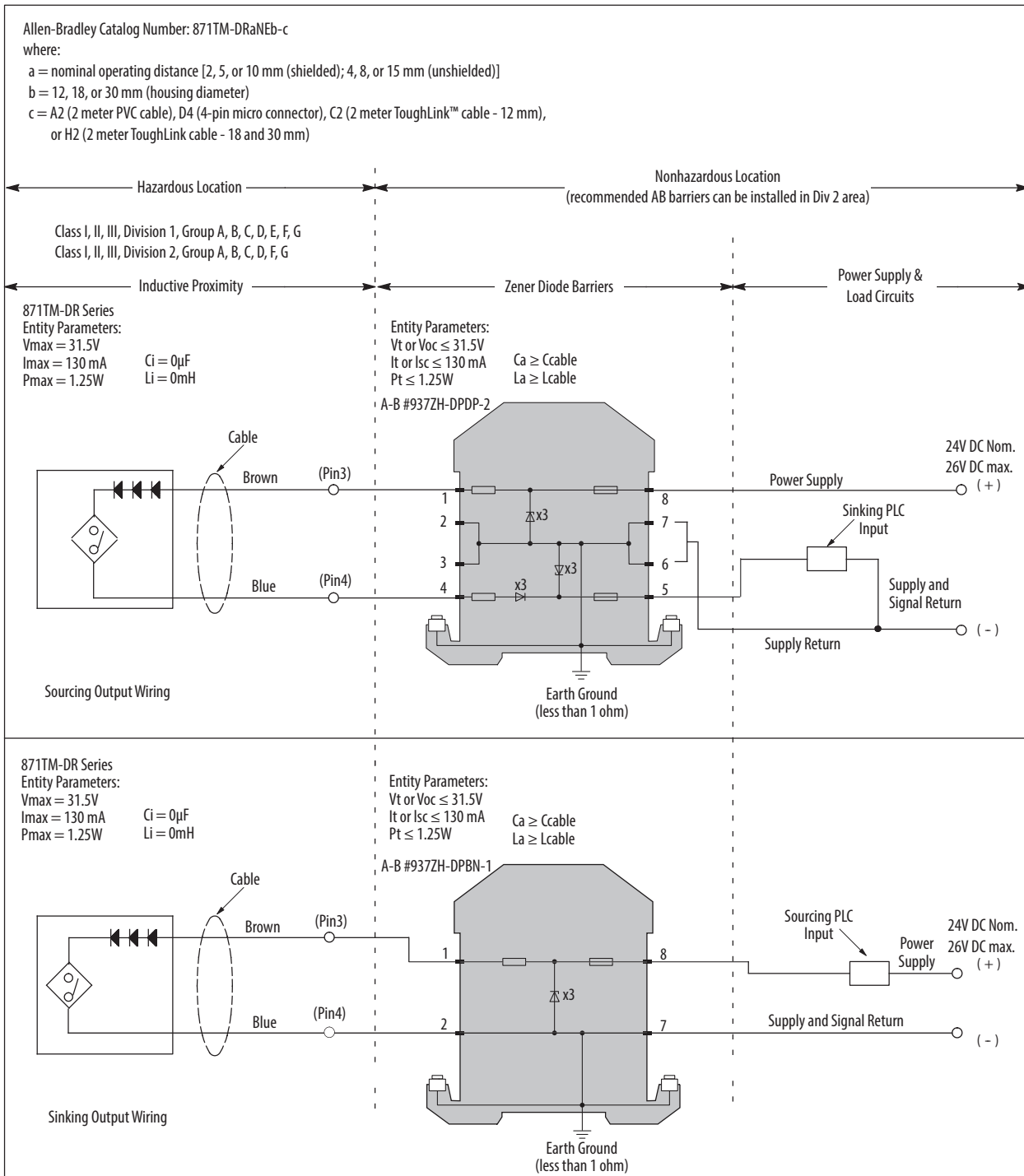

Division 1 Installation Wiring Diagrams (Continued)

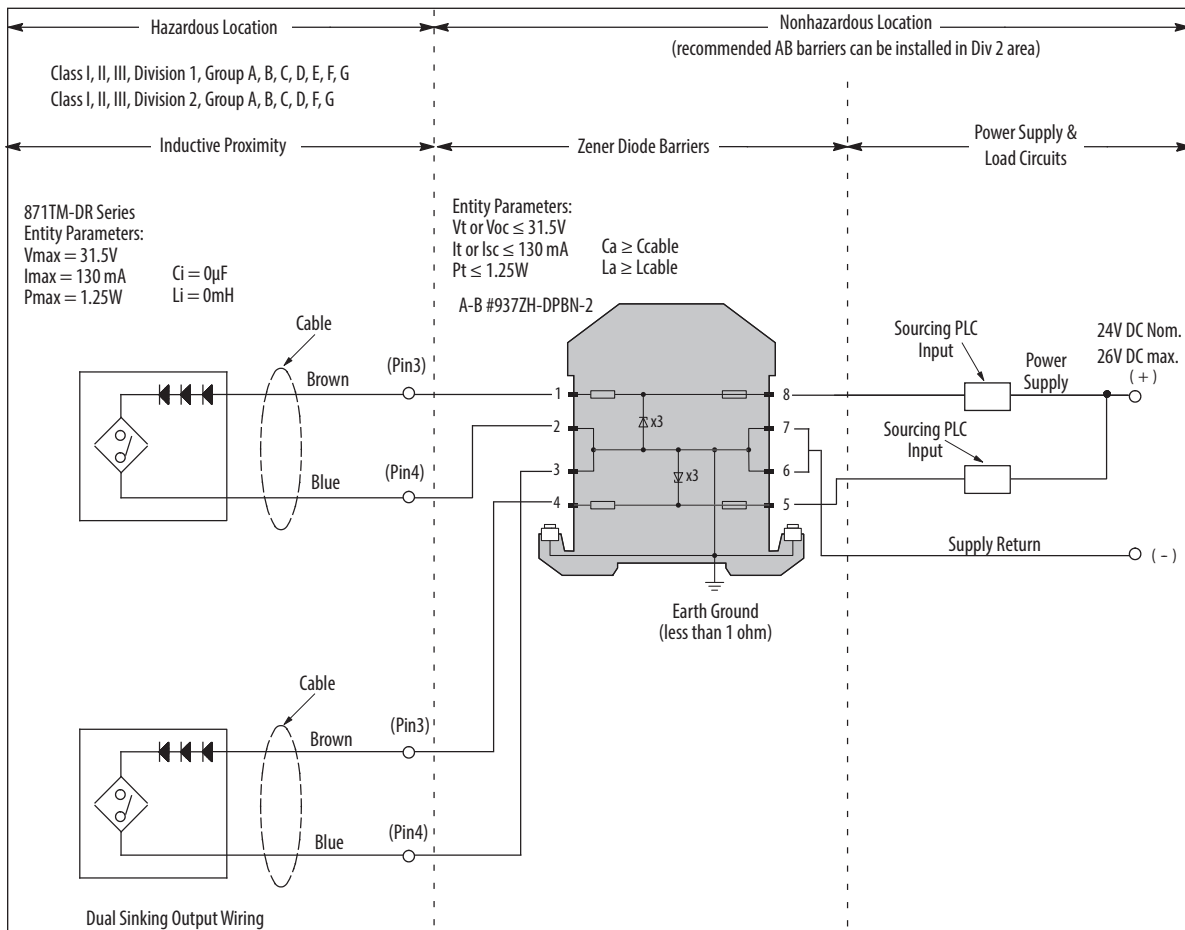

Factory Mutual Installation Notes

- 1 Installation must be in accordance with the National Electrical Code® (NFPA 70, Article 504), ANSI/ISA-RP12.6, and the manufacturer's instructions.
- 2 If the electrical parameters of the cable used are unknown, the following values may be used: Capacitance — 60 pF/ft.; Inductance — 0.20 µH/ft.
- 3 The wiring between each Inductive Proximity Sensor and its corresponding channel of the dual-channel barrier is a separate intrinsically safe circuit. Each of the two separate intrinsically safe circuits shall be in separate cables or shall be separated from each other as specified in NEC 504-30. The supply return conductors may be connected at the barrier's grounding terminal.
- 4 The Barrier bus must be insulated from other grounded metal. Use Power Rail 937A-PR08, 937A-PR20 and Power Feed Module 937A-PSFD.
- 5 The maximum nonhazardous location voltage must not exceed 250V AC or DC.
- 6 Barriers are not required for Division 2 (31.5V DC max.). Division 2 applications must be installed in accordance with the NEC.
- 7 **WARNING:** Substitution of components may impair Intrinsic Safety.
- 8 No revision to drawing without prior FMRC approval.

Canadian Standards Association Installation Notes

- 1 Installation must be in accordance with the Canadian Electrical Code (Part I), ANSI/ISA-RP12.6, and the manufacturer's instructions.
- 2 If the electrical parameters of the cable used are unknown, the following values may be used: Capacitance — 60 pF/ft.; Inductance — 0.20 µH/ft.
- 3 The wiring between each Inductive Proximity Sensor and its corresponding channel of the dual-channel barrier is a separate intrinsically safe circuit. Each of the two separate intrinsically safe circuits shall be in separate cables or shall be separated from each other as specified in CEC. The supply return conductors may be connected at the barrier's grounding terminal.
- 4 The Barrier bus must be insulated from other grounded metal. Use Power Rail 937A-PR08, 937A-PR20 and Power Feed Module 937A-PSFD.
- 5 The maximum nonhazardous location voltage must not exceed 250V AC or DC.
- 6 Barriers are not required for Division 2 (31.5V DC max.). Division 2 applications must be installed in accordance with the CEC.
- 7 In Division 2 applications without barriers observe the following warnings:
WARNING: EXPLOSION HAZARD. Do not disconnect equipment unless power has been switched off or the area is known to be nonhazardous.
WARNING: Substitution of components may impair Intrinsic Safety.
- 8 **WARNING:** Substitution of components may impair Intrinsic Safety.
- 9 No revision to drawing without prior CSA approval.



ATTENTION: These parameters must be adhered to.

871TS Food and Beverage

PPS Plastic Face/Stainless Steel 316L Barrel



871TS DC Micro Quick-disconnect Style
12 mm and 18 mm

Specifications

Attribute	12 mm and 18 mm
Load Current	≤200 mA
Leakage Current	≤15 µA
Operating Voltage	10...30V DC
Voltage Drop	≤2.0V
Repeatability	≤5%
Hysteresis	≤10% typical
Protection Type	False pulse, transient noise, reverse polarity, short circuit, and overload
Certifications	c-UL-us Listed and CE Marked for all applicable directives
Enclosure Type Rating	NEMA 1, 2, 3, 3R, 4, 4X, 6, 6P, 12, 13; IP67, IP68, and IP69K
Housing Material	Stainless steel 316L, PPS (FDA Certified) plastic face
Connection Type	Quick-disconnect: 4-pin micro style
Status Indicator	Yellow: Output Energized
Operating Temperature	-40...+80 °C (-40...+176 °F)
Shock	30 g (1.06 oz), 11 ms
Vibration	55 Hz, 1 mm amplitude, 3 planes

Correction Factors

Target Material	Correction Factors
Steel	1.0
Stainless Steel	0.7...0.8
Brass	0.4...0.5
Aluminum	0.3...0.4
Copper	0.2...0.3

Approximate Dimensions [mm (in.)]

Micro QD Style

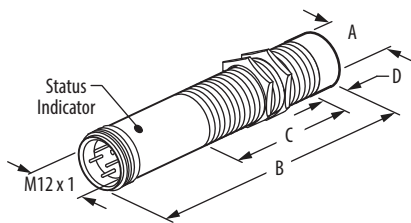

Wiring Diagrams

Normally Open and Normally Closed

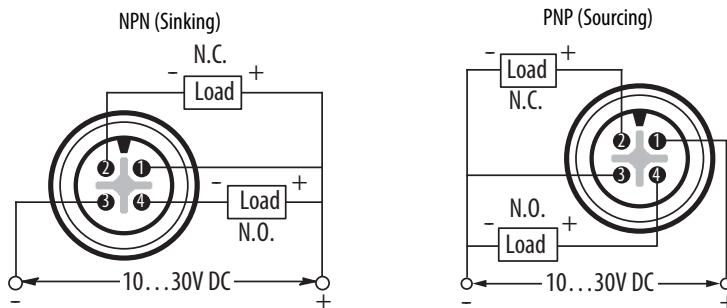

Barrel Type	Thread Size	Shielded	mm (in.)			
			A	B	C	D
Threaded	M12 X 1	Yes	12.0 (0.47)	65.0 (2.56)	38.1 (1.50)	—
		No			32.5 (1.28)	6.5 (0.26)
	M18 X 1	Yes	18.0 (0.71)	63.0 (2.48)	34.5 (1.36)	—
		No			26.5 (1.04)	8.0 (0.31)
Smooth	—	Yes	18.0 (0.71)	63.0 (2.48)	—	—
		No			—	8.0 (0.31)

871Z 3-wire DC Weld Field Immune

PTFE Face/Threaded PTFE-Coated Brass Barrel



871Z DC Mini Quick-disconnect Style
18 mm and 30 mm



871Z DC Micro Quick-disconnect Style
12 mm, 18 mm, and 30 mm

Specifications

Attribute	12 mm, 18 mm, and 30 mm
Load Current	≤200 mA
Load Current, Min.	1 mA
Leakage Current	≤10 μA
Operating Voltage	10...30V DC
Voltage Drop	≤2.4V
Repeatability	≤10%
Hysteresis	≤15% typical
Protection Type	False pulse, transient noise, reverse polarity, short circuit, and overload
Weld Field Immunity	20,000 A at 1 inch
Certifications	CE Marked for all applicable directives
Enclosure Type Rating	NEMA 1, 2, 3, 4, 12 and 13; IP67 (IEC529)
Housing Material	PTFE coated brass barrel
Connection Type	Quick-disconnect: 4-pin mini style, 4-pin micro style
Status Indicator	Red: Output Energized
Operating Temperature	-25...+70 °C (-13...+158 °F)
Shock	30 g (1.06 oz), 11 ms
Vibration	55 Hz, 1 mm amplitude, 3 planes

Correction Factors

Target Material	Correction Factors
Steel	1.0
Stainless Steel	0.7...0.8
Brass	0.4...0.5
Aluminum	0.3...0.4
Copper	0.3...0.4

Approximate Dimensions [mm (in.)]

Mini QD Style

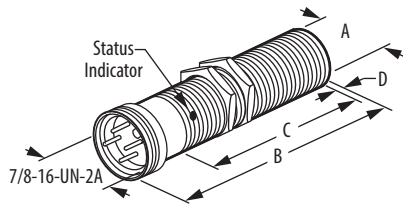

Wiring Diagrams

Normally Open

PNP (Sourcing)

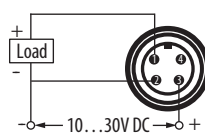

Thread Size	Shielded	mm (in.)		
		A	B	C
M18 x 1	Yes	18.0 (0.71)	90.0 (3.54)	53.0 (2.09)
M30 x 1		30.0 (1.18)	90.0 (3.54)	56.0 (2.20)

Micro QD Style

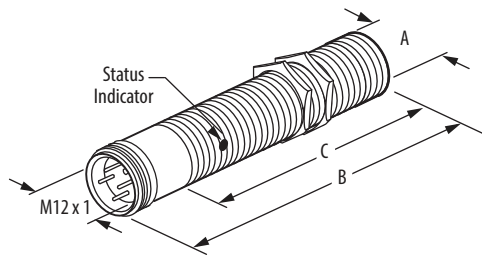

Normally Open

PNP (Sourcing)

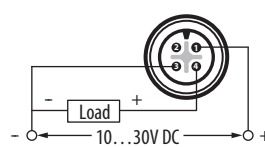

Thread Size	Shielded	mm (in.)		
		A	B	C
M12 x 1	Yes	12.0 (0.47)	70.0 (2.76)	50.0 (1.97)
M18 x 1		18.0 (0.71)	80.0 (3.15)	60.0 (2.36)
M30 x 1		30.0 (1.18)	80.0 (3.15)	60.0 (2.36)

871Z 2-wire AC/DC Weld Field Immune

Thermoset Plastic Face/Threaded PTFE-Coated Brass Barrel



871Z AC/DC Cable Style
18 mm and 30 mm



871Z AC/DC Mini Quick-disconnect Style
12 mm, 18 mm, and 30 mm



871Z AC/DC Micro Quick-disconnect Style
12 mm, 18 mm, and 30 mm

Specifications

Attribute	12 mm	18 mm and 30 mm
Load Current	5...200 mA	5...250 mA
Inrush Current (one cycle)	≤2 A	≤4 A
Leakage Current	≤1.9 mA @ 120V AC	
Operating Voltage	20...250V AC/DC	
Voltage Drop	≤10V @ 5...200 mA	≤10V @ 5...250 mA
Repeatability	≤10% at constant temperature	
Hysteresis	7% typical	
Protection Type	Short circuit (trigger @ 5 A typical), false pulse, reverse polarity (DC output), overload (trigger @ 260 mA typical), and transient noise	Short circuit (trigger @ 8 A typical), false pulse, reverse polarity (DC output), overload (trigger @ 320 mA typical), and transient noise
Weld Field Immunity	20,000 A at 1 inch	
Certifications	UL Listed, CSA Certified, and CE Marked for all applicable directives	
Enclosure Type Rating	NEMA 1, 2, 3, 3R, 4, 4X, 6, 6P, 12, 13; IP67 (IECS29)	
Housing Material	PTFE coated housing	
Connection Type	<ul style="list-style-type: none"> Cable: 2 m (6.5 ft) length H2 - 3 conductor #18 AWG ToughLink Quick-disconnect: 3-pin micro style, 3-pin mini style 	
Status Indicator	<ul style="list-style-type: none"> Red: Output energized Red Flashing: Short circuit/overload Green: Power 	
Operating Temperature	-25...+70 °C (-13...+158 °F)	
Shock	30 g (1.06 oz), 11 ms	
Vibration	55 Hz, 1 mm amplitude, 3 planes	

Correction Factors

Target Material	Correction Factors
Steel	1.0
Stainless Steel	0.7...0.8
Brass	0.4...0.5
Aluminum	0.3...0.4
Copper	0.3...0.4

Approximate Dimensions [mm (in.)]

Cable Style

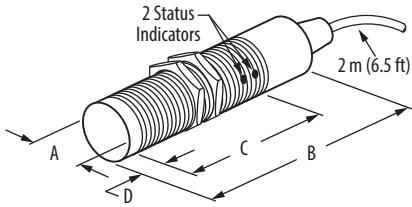

Note: Rear portion of barrel left uncoated for ground contact on 12 mm models

Wiring Diagrams

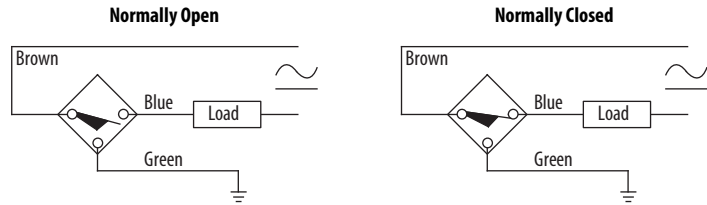

Thread Size	Shielded	mm (in.)			
		A	B	C	D
M18 X 1	Yes	18.0 (0.71)	74.68 (2.94)	61.6 (2.43)	0.8 (0.03)
M30 X 1	No	30.0 (1.18)	77.52 (3.05)	64.3 (2.53)	

Mini QD Style

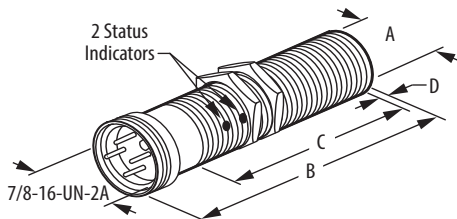

Note: Rear portion of barrel left uncoated for ground contact on 12 mm models.

Normally Open and Normally Closed

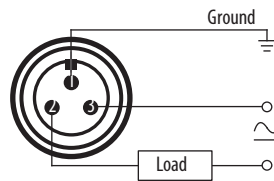

Note: Load can be switched to pin 3.
Note: No ground pin on 12 mm. Attach housing to ground.

Thread Size	Shielded	mm (in.)			
		A	B	C	D
M12 X 1	Yes	12.0 (0.47)	93.45 (3.68)	46.2 (1.82)	0.8 (0.03)
	No			40.7 (1.52)	8.1 (0.32)
M18 X 1	Yes	18.0 (0.71)	75.82 (2.99)	57.28 (2.26)	0.8 (0.03)
M30 X 1	No	30.0 (1.18)	86.66 (3.41)	64.3 (2.53)	0.8 (0.03)

Micro QD Style

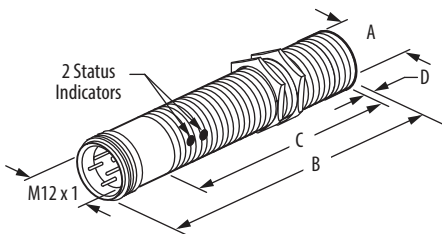

Note: Rear portion of barrel left uncoated for ground contact on 12 mm models.

Normally Open and Normally Closed

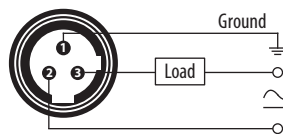

Note: No ground pin on 12 mm. Attach housing to ground.
Note: Load can be switched to pin 3.

Thread Size	Shielded	mm (in.)			
		A	B	C	D
M12 X 1	Yes	12.0 (0.47)	90.1 (3.55)	46.7 (1.85)	0.8 (0.03)
	No			39.7 (1.56)	8.1 (0.32)
M18 X 1	Yes	18.0 (0.71)	83.5 (3.29)	61.6 (2.43)	0.8 (0.03)
M30 X 1	No	30.0 (1.18)	86.0 (3.38)	64.3 (2.53)	0.8 (0.03)

871ZT 3-wire DC Weld Field Immune/Equal Sensing

PTFE Face/Threaded PTFE-coated Brass Barrel



871ZT DC Micro
Quick-disconnect Style
12 mm, 18 mm, and 30 mm

Specifications	
Attribute	12 mm, 18 mm, and 30 mm
Load Current, Max.	200 mA
Load Current, Min.	1 mA
Leakage Current	<0.08 mA
Operating Voltage	10...30V DC
Voltage Drop	≤2.5V
Repeatability	≤5% typical
Hysteresis	≤10% typical
Protection Type	False pulse, transient noise, reverse polarity, short circuit, and overload
Weld Field Immunity	Up to 1260 Gauss (M5)
Certifications	UL Listed and CE Marked for all applicable directives
Enclosure Type Rating	IP67 (IEC 529)
Housing Material	PTFE coated brass barrel
Connection Type	Quick-disconnect: 4-pin micro style
Status Indicator	360° status indicator visibility; Orange: Target present
Operating Temperature	-25...+70 °C (-13...+158 °F)
Shock	30 g (1.06 oz), 11 ms
Vibration	55 Hz, 1 mm amplitude, 3 planes

Correction Factors	
Target Material	Correction Factors
Steel	1.0
Stainless Steel	0.9...1.1
Brass	0.9...1.1
Aluminum	0.9...1.1
Copper	0.9...1.1

Approximate Dimensions [mm (in.)]

Micro QD Style

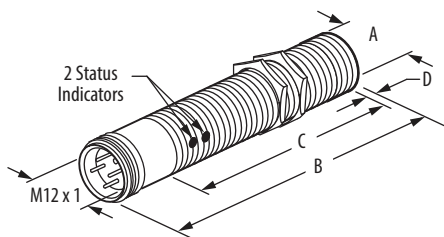

Wiring Diagrams

Normally Open

PNP (Sourcing)

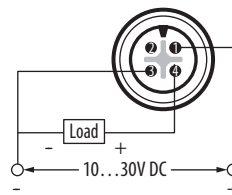

Thread Size	Shielded	mm (in.)			
		A	B	C	D
M12 X 1	Yes	12.0 (0.47)	65.0 (2.56)	50.0 (1.97)	—
	No			40.0 (1.58)	10.0 (0.39)
M18 X 1	Yes	—		50.0 (1.97)	—
	No	18.0 (0.71)		40.5 (1.59)	10.0 (0.39)
M30 X 1	Yes	—		50.5 (1.99)	—
	No	30.0 (1.18)		37.5 (1.48)	13.0 (0.51)

872C WorldProx™ 3- and 4-wire DC Tubular Sensors

Plastic Face/Threaded Nickel-plated Brass Barrel



DC Micro Quick-disconnect Style
8 mm, 12 mm, 18 mm, and 30 mm



DC Pico Quick-disconnect Style
6.5 mm, 8 mm, and 12 mm



DC Cable Style
6.5 mm, 8 mm, 12 mm, 18 mm, and 30 mm



Pigtail Cable with Integral Micro QD Connector
8 mm, 12 mm, 18 mm, and 30 mm

Specifications

Attribute	8 mm	12 mm	18 mm	30 mm
Load Current	≤100 mA	≤200 mA		
Leakage Current	≤5 μA	≤10 μA		
Operating Voltage	5...30V DC	10...30V DC		
Voltage Drop	≤1.5V	≤1.8V		
Switching Frequency	≤2500 Hz	≤1300 Hz ⁽¹⁾	≤1500 Hz ⁽¹⁾	≤1000 Hz ⁽¹⁾
No-load Supply Current	≤10 mA			
Repeatability	≤5%			
Hysteresis	≤10% typical			
Protection Type	False pulse on power, transient noise, reverse polarity, short circuit, and overload			
Certifications	c-UL-us Listed and CE Marked for all applicable directives			
Enclosure Type Rating	IP67			
Housing Material	Nickel-plated brass barrel nuts with integral locking feature, plastic face (LCP)		Nickel-plated brass barrel nuts with integral locking feature, plastic face (PBT)	
Connections	<ul style="list-style-type: none"> Cable (PVC/PUR): 2 m (6.5 ft), 5 m (16.4 ft), 10 m (32.8 ft) length, 3.5 mm (0.175 in.) dia. (PVC); 3.3 mm dia. (PUR); 3 x 0.14 mm² PVC or PP Cable (Pigtail): 0.2 m (0.7 ft), 0.5 m (1.6 ft), 1 m (3.3 ft) length Connector: 3-pin M12 or 3-pin M8 		<ul style="list-style-type: none"> Cable (PVC/PUR): 2 m (6.5 ft), 5 m (16.4 ft), 10 m (32.8 ft) length, 4.3 mm (0.17 in.) diameter; 3x 0.34 mm² (0.01 in.²) or 4x 0.34 mm² PVC or PUR Cable (Pigtail): 0.2 m (0.7 ft), 0.5 m (1.6 ft), 1 m (3.3 ft) length, Integral connector (M12) 3- or 4-pin micro QD Quick-disconnect: 3- or 4-pin micro QD (M12) or [3-pin pico QD (M8) for 12 mm only] 	
Status Indicator	Amber: output energized		Amber: output energized	
Operating Temperature	-25...+70 °C (-13...+158 °F)			
Shock	30 g (1.06 oz), 11 ms half-sine			
Vibration	55 Hz, 1 mm amplitude, 3 planes			

Nominal Sensing Distance (mm [in.])

Size	Description	Standard Sensing Range	Extended Sensing Range
6.5 mm	Shielded	2 (0.08)	—
	Unshielded	3 (0.12)	—
8 mm	Shielded	2 (0.08)	3 (0.12)
	Unshielded	3 (0.12)	4 (0.16)
12 mm	Shielded	3 (0.12)	4 (0.16)
	Unshielded	4 (0.16)	8 (0.31)
18 mm	Shielded	5 (0.20)	8 (0.31)
	Unshielded	8 (0.31)	12 (0.47)
30 mm	Shielded	10 (0.39)	15 (0.59)
	Unshielded	15 (0.59)	20 (0.79)

Correction Factors (mm [in.])

Target Material	6.5 mm	8 mm	12 mm	18 mm	30 mm
Steel	1.0	1.0	1.0	1.0	1.0
Stainless Steel	0.7...0.8	0.7...0.8	0.7...0.8	0.7...0.8	0.7...0.8
Brass	0.45...0.55	0.45...0.55	0.45...0.55	0.45...0.55	
Aluminum	0.3...0.4	0.45...0.55	0.45...0.55	0.4...0.5	0.45...0.55
Copper	0.2...0.3	0.35...0.45	0.35...0.45	0.3...0.45	0.35...0.45

(1) Select 3-wire models have switching frequency less than previously specified:
 12 mm diameter shielded, extended range, N.O., PNP, micro QD ≤800 Hz
 12 mm diameter unshielded, extended range, N.O., PNP, micro QD ≤1000 Hz
 18 mm diameter shielded, extended range, N.O., PNP, micro QD, and cable ≤500 Hz
 30 mm diameter shielded, extended range, N.O., PNP, micro QD <100 Hz at SD = 7.5 mm (0.3 in.), 200 Hz at SD = 10 mm (0.39 in.)

872C WorldProx 3- and 4-wire DC Tubular Sensors

Plastic Face/Threaded Nickel-plated Brass Barrel

8 mm, 12 mm, 18 mm, and 30 mm Pinouts

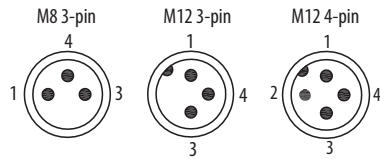

1 BN (brown) 2 WH (white) 3 BU (blue) 4 BK (black)

8 mm, 12 mm, 18 mm, and 30 mm 3-wire DC Wiring

NPN/PNP	Cable	M12 Micro Connector	M8 Pico Connector
NPN N.O.			
NPN N.C.			
PNP N.O.			
PNP N.C.			

12 mm, 18 mm, and 30 mm 4-wire DC Complementary Wiring

NPN/PNP	Cable	M12 Micro Connector	M8 Pico Connector
NPN N.O. + N.C. Complementary			
PNP N.O. + N.C. Complementary			

872C WorldProx 3- and 4-wire DC Tubular Sensors — Standard and Extended Sensing

Plastic Face/Threaded Nickel-plated Brass Barrel — Standard Barrel Length

Cable Style Approximate Dimensions

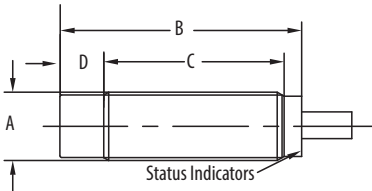
Dimensions [mm (in.)]	Thread Size	Barrel Type	Smooth Diameter	Shielded	mm (in.)			
					A	B (Max)	C (Min)	D (Max)
	—	Nickel-plated Brass	6.5 ⁽¹⁾	Yes	6.50 (0.26)	33.0 (1.30)	—	—
	M8 X 1	Nickel-plated Brass	—	Yes	8.00 (0.31)	30.0 (1.18)	30.2 (1.19)	—
				No	—	35.0 (1.38)		5.0 (0.20)
	M12 X 1	Nickel-plated Brass	—	Yes	12.0 (0.47)	50.8 (2.00)	46.7 (1.84)	—
				No	—	58.8 (2.31)		8.0 (0.31)
	M18 X 1	Nickel-plated Brass	—	Yes	18.0 (0.71)	50.8 (2.00)	46.7 (1.84)	—
				No	—	60.8 (2.39)		10.0 (0.39)
	M30 X 1	Nickel-plated Brass	—	Yes	30.0 (1.18)	50.8 (2.00)	47.8 (1.88)	—
				No		—		63.0 (2.48)

(1) 6.5 mm diameter is standard only

Micro QD Style Approximate Dimensions

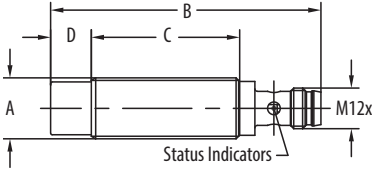
Dimensions [mm (in.)]	Thread Size	Barrel Type	Shielded	mm (in.)			
				A	B (Max)	C (Min)	D (Max)
	M8 X 1	Nickel-plated Brass	Yes	8.00 (0.31)	55.0 (2.16)	30.0 (1.18)	—
			No		60.0 (2.36)		5.00 (0.20)
	M12 X 1	Nickel-plated Brass	Yes	12.0 (0.47)	64.3 (2.53)	38.1 (1.50)	—
			No	—	72.3 (2.85)		8.0 (0.31)
	M18 X 1	Nickel-plated Brass	Yes	18.0 (0.71)	65.5 (2.58)	38.1 (1.50)	—
			No	—	75.5 (2.97)		10.0 (0.39)
	M30 X 1.5	Nickel-plated Brass	Yes	30.0 (1.18)	64.3 (2.53)	48.3 (1.90)	—
			No		—		76.5 (3.01)

Pico QD Style Approximate Dimensions

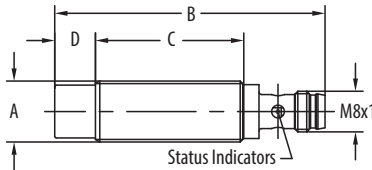
Dimensions [mm (in.)]	Thread Size	Barrel Type	Smooth Diameter	Shielded	mm (in.)			
					A	B (Max)	C (Min)	D (Max)
	—	Nickel-plated Brass	6.5 ⁽¹⁾	Yes	6.50 (0.26)	49.0 (1.93)	—	—
	M8 X 1		Yes	8.0 (0.31)	50.0 (1.97)	35.0 (1.38)	—	
			No		—		55.0 (2.16)	5.0 (0.20)
	M12 X 1		Nickel-plated Brass	Yes	12.0 (0.47)	63.5 (2.50)	47.5 (1.87)	—
				No	—	71.5 (2.81)		8.0 (0.31)

(1) 6.5 mm diameter is standard only

872C WorldProx 3- and 4-wire DC Tubular Sensors — Standard and Extended Sensing

Plastic Face/Threaded Nickel-plated Brass Barrel — Short Barrel Length

Cable Style Approximate Dimensions

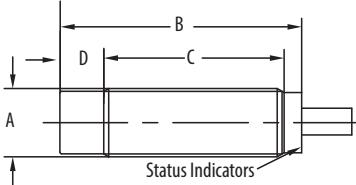
Dimensions	Thread Size	Barrel Type	Shielded	mm (in.)			
				A	B (Max)	C (Min)	D (Max)
	M8 X 1	Nickel-plated Brass	Yes	8.0 (0.31)	25.0 (0.98)	25.0 (0.98)	—
			No		30.0 (1.18)		5.0 (0.2)
	M12 X 1		Yes	12.0 (0.47)	34.8 (1.37)	31.8 (1.25)	—
			No		42.8 (1.68)		8.0 (0.31)
	M18 X 1		Yes	18.0 (0.71)	34.8 (1.37)		—
			No		44.8 (1.76)		10.0 (0.39)
	M30 X 1		Nickel-plated Brass	Yes	30.0 (1.18)	34.8 (1.37)	—
				No		47.0 (1.85)	26.0 (1.02)

Micro Style Approximate Dimensions

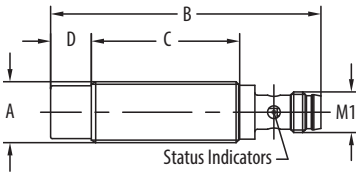
Dimensions	Thread Size	Barrel Type	Shielded	mm (in.)				
				A	B (Max)	C (Min)	D (Max)	
	M8 X 1	Nickel-plated Brass	Yes	8.0 (0.31)	45.0 (1.77)	20.0 (0.79)	—	
			No		50.0 (1.97)		5.0 (0.20)	
	M12 X 1		Yes	12.0 (0.47)	48.3 (1.90)	27.4 (1.08)	—	
			No		56.4 (2.22)		8.0 (0.31)	
	M18 X 1		Yes	18.0 (0.71)	49.5 (1.95)		26.4 (1.04)	—
			No		59.5 (2.34)		10.0 (0.39)	
	M30 X 1.5		Nickel-plated Brass	Yes	30.0 (1.18)	50.8 (2.00)	31.8 (1.25)	—
				No		63.2 (2.49)	29.2 (1.15)	18.0 (0.71)

Pico Style Approximate Dimensions

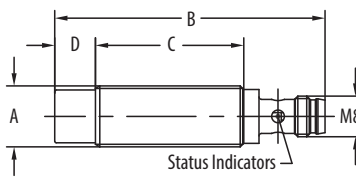
Dimensions	Thread Size	Barrel Type	Shielded	mm (in.)			
				A	B (Max)	C (Min)	D (Max)
	M8 X 1	Nickel-plated Brass	Yes	8.0 (0.31)	45.0 (1.77)	30.0 (1.18)	—
			No		50.0 (1.97)		5.0 (0.2)
	M12 X 1		Yes	12.0 (0.47)	45.2 (1.78)	29.2 (1.15)	—
			No		53.2 (2.10)		8.0 (0.31)

802PR 2-wire AC, High-output Rectangular Sensors

Limit Switch Style



802PR AC Conduit Style



802PR AC Cable Style



802PR AC Mini QD Style

Specifications

Attribute	802PR
Load Current	≤1 A at 40 °C (104 °F) linearly de-rated to 0.5 A at 75 °C (167 °F)
Inrush Current	≤10 A/1 s
Current Consumption	25 mA, min.
Leakage Current	≤3.5 mA (60...132V AC); ≤6.5 mA (102...132V AC)
Operating Voltage	60...132V AC or 102...132V AC
Voltage Drop	≤8.5V
Repeatability	≤0.025 mm
Hysteresis	15% (max.)
Protection Type	False pulse, transient noise
Certifications	UL Listed, CSA Certified, and CE Marked for all applicable directives
Enclosure Type Rating	NEMA 1, 2, 3, 4, 4X, 12, 13, IP65 (IECS29)
Housing Material	Self-extinguishing glass reinforced polyester body
Connection Type	<ul style="list-style-type: none"> Cable: 2.4 m (8 ft) or 3.7 m (12 ft) length, 2-conductor 16 AWG STO (oil-resistant thermoplastic) Quick-disconnect: 3-pin mini; Conduit Opening or Conduit Coupler: 1/2-14 NPT internal thread with screw terminals (use #18...14 AWG wire)
Status Indicator	Red: Output energized
Operating Temperature	-25...+75 °C (-13...+167 °F)
Shock	30 g (1.06 oz), 11 ms
Vibration	55 Hz, 1 mm amplitude, 3 planes

Correction Factors

Target Material	Correction Factors
Steel	1.0
Stainless Steel	0.8...0.85
Brass	0.5...0.55
Aluminum	0.45...0.5
Copper	0.4...0.45

Approximate Dimensions [mm (in.)]

Cable Style

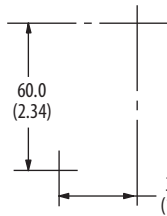
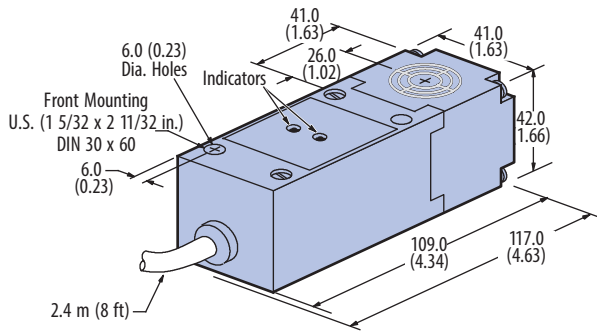

Front Mounting Hole Pattern Front View
Two Holes for #10 or M5 Screws

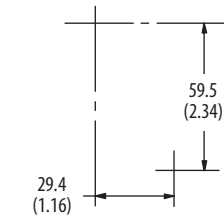

Rear Mounting Hole Pattern Front View
Two #10-32 Tapped Holes 9.5 (0.38)
Deep (LB Version Only)

Wiring Diagrams

Normally Open

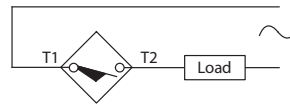

Note: Load can be switched to white lead.

Wiring Diagrams

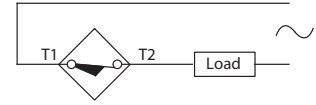

Mini QD Style

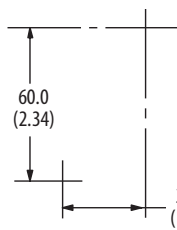
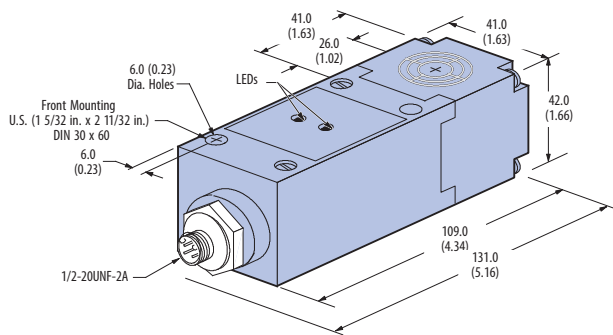

Front Mounting Hole Pattern Front View
Two Holes for #10 or M5 Screws

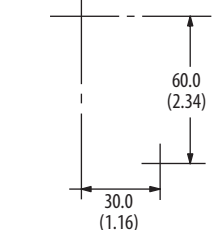

Rear Mounting Hole Pattern Front View
Two #10-32 Tapped Holes 9.5 (0.38)
Deep (LB Version Only)

Normally Open or Normally Closed

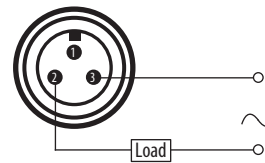

Note: Load can be switched to pin 3.

Note 1: Side sensing model heads can be turned in 90° increments to accommodate four side-sensing positions.

Note 2: Low voltage models have two status indicators.

Approximate Dimensions [mm (in.)]

Cable Style

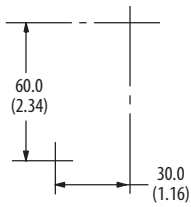
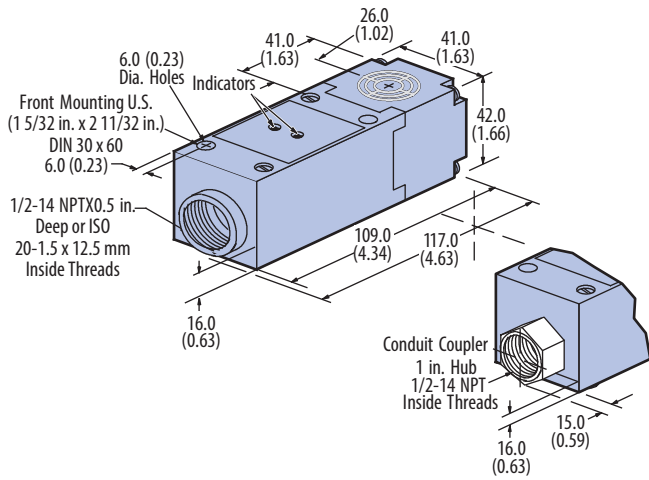

Front Mounting Hole Pattern Front View
Two Holes for #10 or M5 Screws

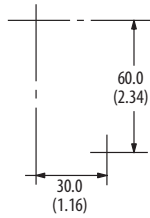

Rear Mounting Hole Pattern Front View
Two #10-32 Tapped Holes 9.5 (0.38) Deep (LB Version Only)

Wiring Diagrams

Normally Open

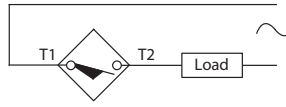

Normally Closed

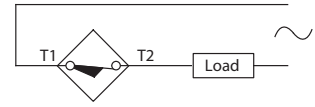

Note: Load can be switched to terminal 1

Note 1: Side sensing model heads can be turned in 90° increments to accommodate four side-sensing positions.

Note 2: Low voltage models have two status indicators.

802PR 2-wire AC Hazardous Location, High-output Rectangular Sensors

Limit Switch Style



802PR AC Conduit Style

Specifications

Attribute	802PR
Load Current	≤1 A at 40 °C (104 °F) linearly derated to 0.5 A at 75 °C (167 °F)
Inrush Current	≤10 A/1 s
Current Consumption	25 mA, min.
Leakage Current	≤6.5 mA
Operating Voltage	102...132V AC
Voltage Drop	≤8.5V
Repeatability	≤0.025 mm
Hysteresis	15% (max.)
Protection Type	False pulse, transient noise
Certifications	UL Listed and CSA Certified
Enclosure Type Rating	NEMA 1, 2, 3, 4, 12, 13; IP65 (IEC529) Division 2 Class I: Groups A, B, C, and D; Class II: Groups F and G; Class III: All groups
Housing Material	Self-extinguishing glass reinforced polyester body
Connection Type	Conduit Coupler: 1/2 -14NPT internal thread with screw terminals (use #18...14 AWG wire)
Status Indicator	Red: Output energized
Operating Temperature	-25...+75 °C (-13...+167 °F)
Shock	30 g (1.06 oz), 11 ms
Vibration	55 Hz, 1 mm amplitude, 3 planes

Correction Factors

Target Material	Correction Factors
Steel	1.0
Stainless Steel	0.8...0.85
Brass	0.5...0.55
Aluminum	0.45...0.5
Copper	0.4...0.45

Approximate Dimensions [mm (in.)]

Conduit Style

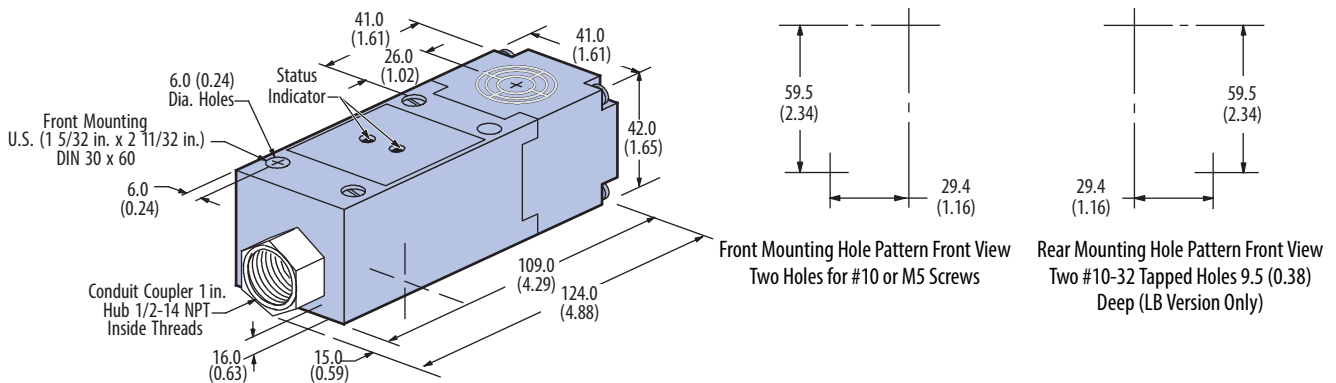

Note: Side sensing model heads can be turned in 90° increments to accommodate four side-sensing positions.

2-wire AC/DC Rectangular Sensors

Limit Switch Style



802PR AC/DC Cable Style



802PR AC/DC Mini Quick-disconnect Style



802 AC/DCM Quick-disconnect Style



802PR AC/DC Conduit Style

Specifications

Attribute	802
Load Current	AC 4...25 mA; DC 2...25 mA
Leakage Current	≤1.7 mA at 132V, ≤2.5 mA at 250V
Operating Voltage	20...250V AC/DC
Voltage Drop	≤10V
Repeatability	≤10% typical
Hysteresis	≤10% typical
Protection Type	Transient noise, short circuit, overload, false pulse, radio frequency (10V per meter; frequency range 20...1000 MHz)
Certifications	UL Listed, CSA Certified, and CE Marked for all applicable directives
Enclosure Type Rating	NEMA 1, 2, 3, 4, 4X, 12, 13, IP65 (IECS29)
Housing Material	Self-extinguishing glass-reinforced polyester body
Connection Type	<ul style="list-style-type: none"> Cable: 2.4 m (8 ft) length, 2-conductor ToughLink Quick-disconnect: 3-pin micro style, 3-pin mini style Conduit Opening or Conduit Coupler: Internal thread with screw terminals (use #18...14 AWG wire)
Status Indicator	<ul style="list-style-type: none"> Green: Power Red: Output energized (both on in SCP/overload)
Operating Temperature	-25...+75 °C (-13...+167 °F)
Shock	30 g (1.06 oz), 11 ms
Vibration	55 Hz, 1 mm amplitude, 3 planes

Correction Factors

Target Material	Correction Factors
Steel	1.0
Stainless Steel	0.9
Brass	0.8
Aluminum	0.75
Copper	0.7

Approximate Dimensions [mm (in.)]

Cable Style

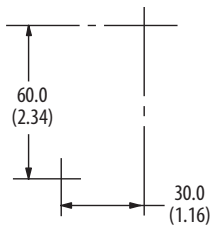
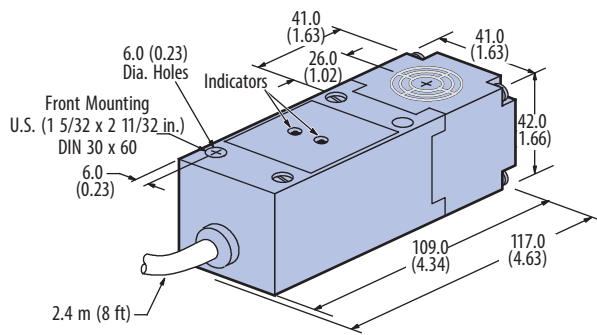

Front Mounting Hole Pattern Front View
Two Holes for #10 or M5 Screws

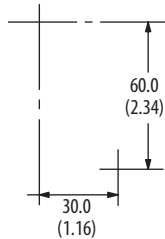

Rear Mounting Hole Pattern Front View
Two #10-32 Tapped Holes 9.5 (0.38) Deep (LB Version Only)

Wiring Diagrams

Normally Open

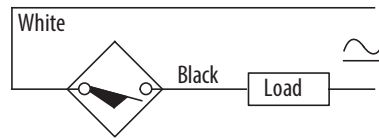

Note: Load can be switched to white lead.

Mini QD Style

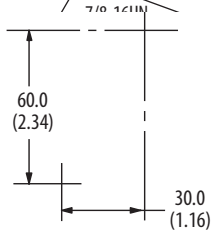
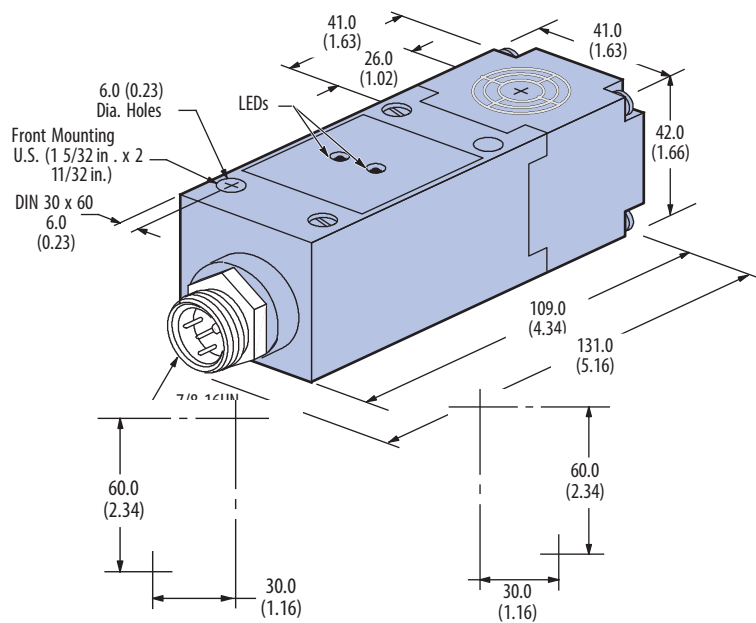

Front Mounting Hole Pattern Front View
Two Holes for #10 or M5 Screws

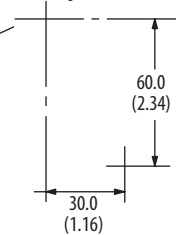

Rear Mounting Hole Pattern Front View
Two #10-32 Tapped Holes 9.5 (0.38) Deep (LB Version Only)

Normally Open

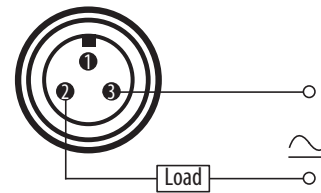

Note: Load can be switched to pin 3.

Approximate Dimensions [mm (in.)]

Micro Style

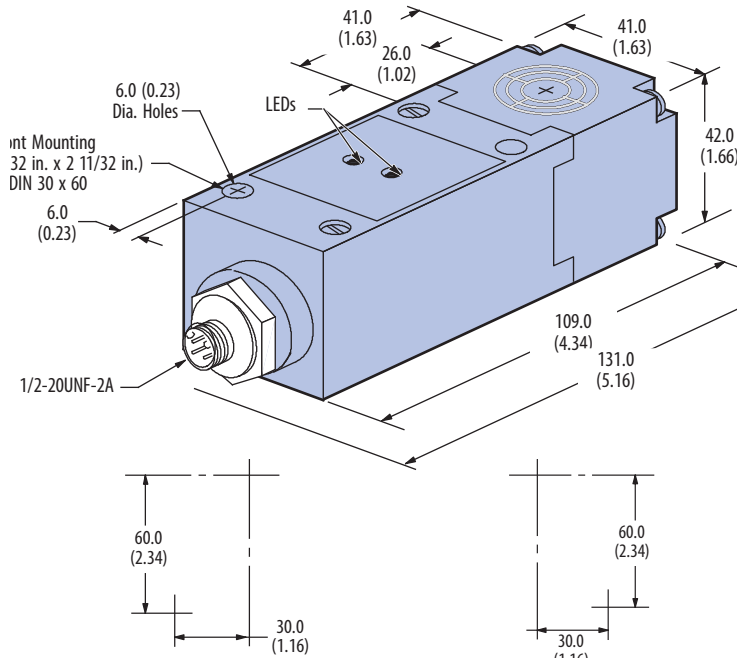

Front Mounting Hole Pattern Front View
Two Holes for #10 or M5 Screws

Rear Mounting Hole Pattern Front View
Two #10-32 Tapped Holes 9.5 (0.38)
Deep (LB Version Only)

Wiring Diagrams

Normally Open

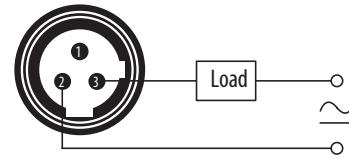

Note: Load can be switched to pin 2.

Conduit QD Style

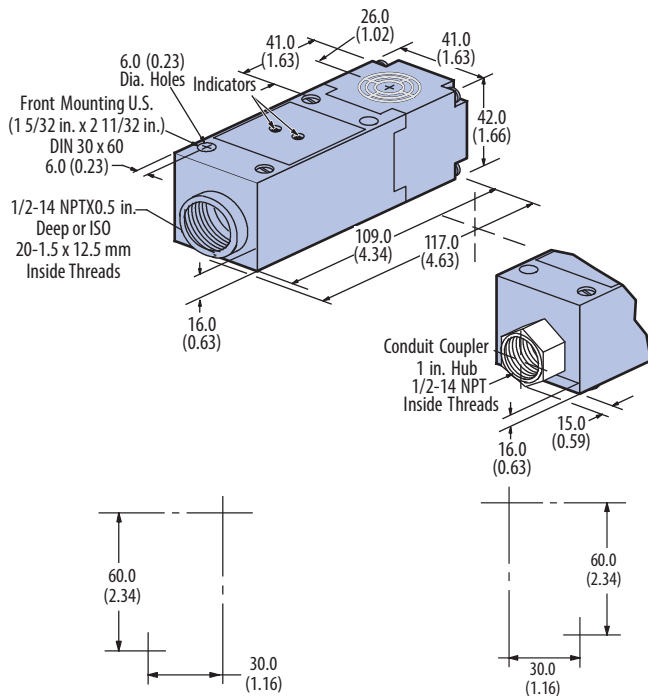

Front Mounting Hole Pattern Front View
Two Holes for #10 or M5 Screws

Rear Mounting Hole Pattern Front View
Two #10-32 Tapped Holes 9.5 (0.38)
Deep (LB Version Only)

Normally Open

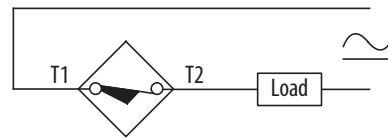

Note: Load can be switched to terminal 1.

Note: Side sensing model heads can be turned in 90° increments to accommodate four side-sensing positions.

802PR 2-wire AC/DC Hazardous Location Rectangular Sensors

Limit Switch Style



802PR AC Conduit Style

Specifications

Attribute	802PR
Load Current	AC: 4...25 mA, DC: 2...25 mA
Leakage Current	≤1.7 mA at 132V, ≤2.5 mA at 250V
Operating Voltage	20...250V AC/DC
Voltage Drop	≤10V
Repeatability	≤10% typical
Hysteresis	≤10% typical
Protection Type	Transient noise, short circuit, overload, false pulse, radio frequency (≤10V per meter; frequency range 20...1000 MHz)
Certifications	UL Listed and CSA Certified
Enclosure Type Rating	NEMA 1, 2, 3, 4, 12, 13; IP65 (IEC529); Division 2 Class I: Groups A, B, C, and D; Class II: Groups F and G; Class III: All groups
Housing Material	Self-extinguishing glass-reinforced polyester body
Connection Type	Conduit Coupler: 1/2 - 14 NPT internal thread with screw terminals, use #18...14 AWG wire
Status Indicator	<ul style="list-style-type: none"> Green: Power Red: Output energized (both on in SCP/Overload)
Operating Temperature	-25...+75 °C (-13...+167 °F)
Shock	30 g (1.06 oz), 11 ms
Vibration	55 Hz, 1 mm amplitude, 3 planes

Correction Factors

Target Material	Correction Factors
Steel	1.0
Stainless Steel	0.9
Brass	0.8
Aluminum	0.75
Copper	0.7

Approximate Dimensions [mm (in.)]

Conduit Style

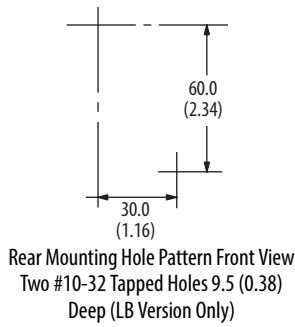
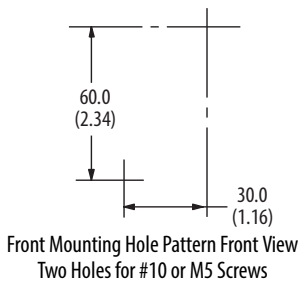
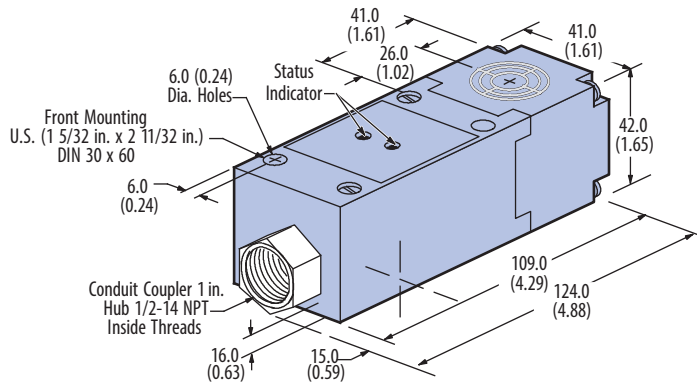

Wiring Diagrams

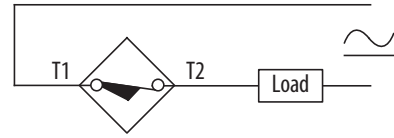

Note: Load can be switched to terminal 1.

Note: Side sensing model heads can be turned in 90° increments to accommodate four side-sensing positions.

871F 3-wire DC Rectangular Sensors

Block Style



871F DC Cable Style

871F DC Micro
Quick-disconnect Style

Specifications

Attribute	871F
Load Current	≤400 mA
Load Current, Min.	1 mA
Leakage Current	≤10 μA
Operating Voltage	10...30V DC
Voltage Drop	≤2.4V
Repeatability	≤10%
Hysteresis	≤15% typical
Protection Type	False pulse, transient noise, reverse polarity, short circuit, and overload
Certifications	CE Marked for all applicable directives
Enclosure Type Rating	NEMA 1, 2, 3, 4, 12, 13; IP67 (IEC529)
Housing Material	Aluminum body
Connection Type	<ul style="list-style-type: none"> Cable: 2 m (6.5 ft) length, 3-conductor PVC Quick-disconnect: 4-pin micro style
Indicator Status Indicators	Orange: Output energized
Operating Temperature	-25...+70 °C (-13...+158 °F)
Shock	30 g (1.06 oz), 11 ms
Vibration	55 Hz, 1 mm amplitude, 3 planes

Correction Factors

Target Material	Correction Factors
Steel	1.0
Stainless Steel	0.7...0.8
Brass	0.4...0.5
Aluminum	0.3...0.4
Copper	0.2...0.3

Approximate Dimensions [mm (in.)]

Cable Style

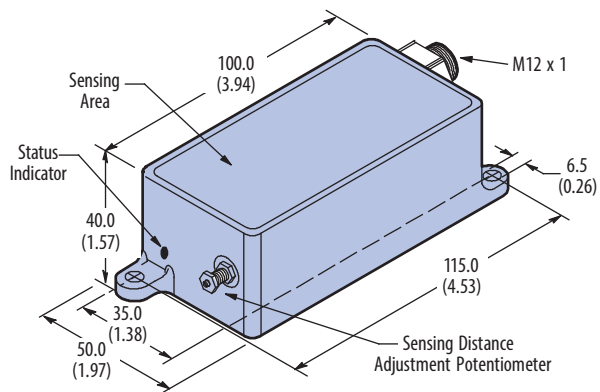
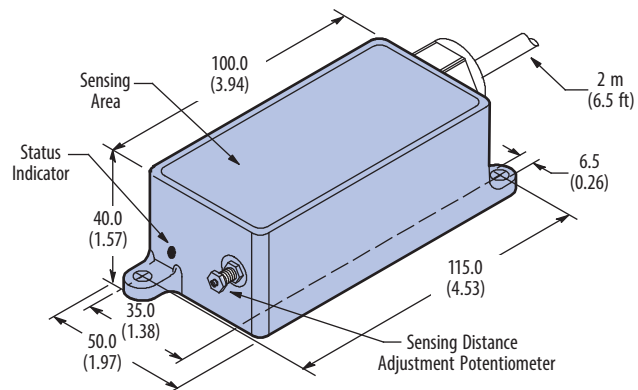

Wiring Diagrams

Normally Open

PNP (Sourcing)

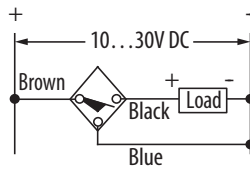

NPN (Sinking)

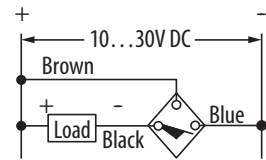

PNP (Sourcing)

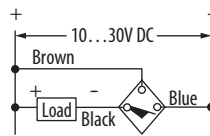

NPN (Sinking)

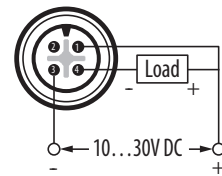

871F 4-wire DC Complementary Output Rectangular Sensors

Flat Pack Style



871F DC Mini
Quick-disconnect Style



871F DC Micro
Quick-disconnect Style

Specifications

Attribute	871F
Load Current, Max.	200 mA
Load Current, Min.	1 mA
Leakage Current	≤10 μA
Operating Voltage	10...30V DC
Voltage Drop	≤2.5V
Repeatability	≤2%
Hysteresis	≤5% typical
Protection Type	False pulse, transient noise, reverse polarity, short circuit, overload
Certifications	c-UL-us Listed and CE Marked for all applicable all directives
Enclosure Type Rating	NEMA 1, 2, 3, 4, 6, 6P, 12 and 13; IP67 (IEC529), 1200 psi (8270 kPa) washdown; micro connector versions also meet IP69K (IEC529)
Connection Type	<ul style="list-style-type: none"> Quick-disconnect: 4-pin mini, 4-pin micro Conduit Opening: 1/2 - 14NPT thread, PG 13.5 thread
Status Indicator	<ul style="list-style-type: none"> Green: Power Orange: Output energized
Operating Temperature	-25...+70 °C (-13...+158 °F)
Shock	30 g (1.06 oz), 11 ms
Vibration	55 Hz, 1 mm amplitude, 3 planes

Correction Factors

Target Material	Correction Factors
Steel	1.0
Stainless Steel	0.7...0.8
Brass	0.4...0.5
Aluminum	0.3...0.4
Copper	0.2...0.3

Approximate Dimensions [mm (in.)]

Mini QD Style

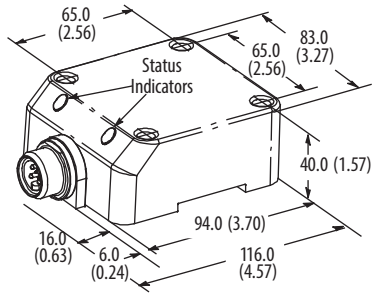

Micro QD Style

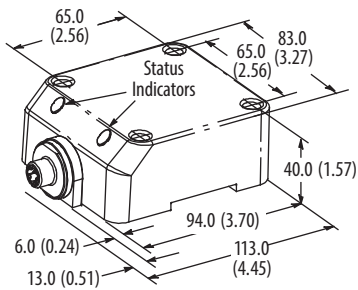

Conduit Style 1/2 in. NPT

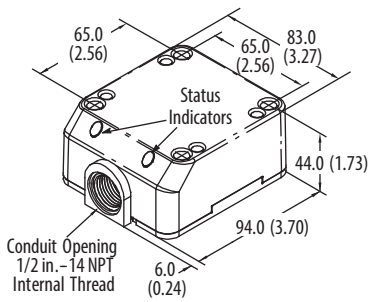

Conduit Style PG13.5

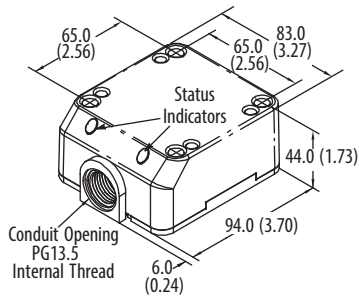

Wiring Diagrams

Complimentary Normally Open and Closed Outputs

PNP (Sourcing)

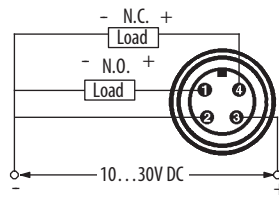

NPN (Sinking)

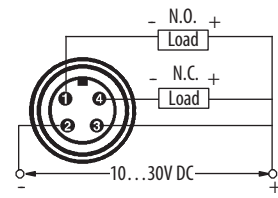

PNP (Sourcing)

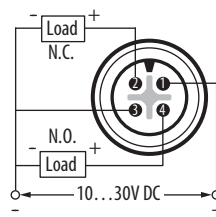

NPN (Sinking)

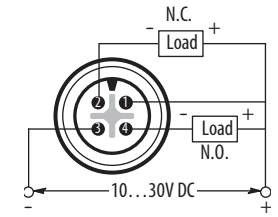

PNP (Sourcing)

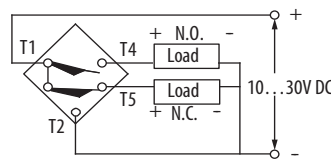

NPN (Sinking)

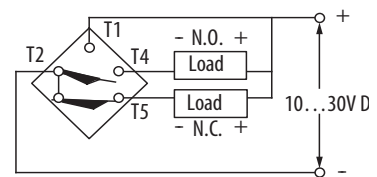

PNP (Sourcing)

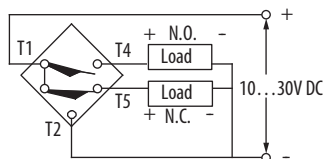

NPN (Sinking)

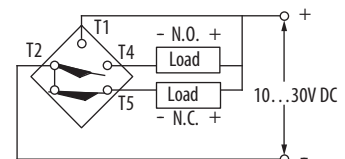

871F 2-wire AC/DC Rectangular Sensors

Flat Pack Style



871F AC/DC
Cable Style



871F DC Mini
Quick-disconnect Style



871F DC Micro
Quick-disconnect Style

Specifications

Attribute	871F
Load Current, Max.	100 mA
Load Current, Min.	5 mA
Leakage Current	≤1.7 mA @ 120V; ≤2.0 mA @ 250V
Operating Voltage	20...250V AC/DC
Voltage Drop	≤10V
Repeatability	≤5%
Hysteresis	≤10% typical
Protection Type	False pulse, transient noise, short circuit, and overload
Certifications	c-UL-us Listed and CE Marked for all applicable all directives
Enclosure Type Rating	NEMA 1, 2, 3, 4, 6, 6P, 12 and 13; IP67 (IEC529), 1200 psi (8270 kPa) washdown; micro connector versions also meet IP69K (IEC529)
Connection Type	<ul style="list-style-type: none"> Cable: 2 m (6.5 ft), 2-conductor #22 AWG ToughLink; Quick-disconnect: 3-pin mini style, 3-pin micro style; Conduit Opening: 1/2 - 14NPT thread, PG 13.5 thread
Status Indicator	<ul style="list-style-type: none"> Green: Power Orange: Output energized
Operating Temperature	-25...+70 °C (-13...+158 °F)
Shock	30 g (1.06 oz), 11 ms
Vibration	55 Hz, 1 mm amplitude, 3 planes

Correction Factors

Target Material	Correction Factors
Steel	1.0
Stainless Steel	0.7...0.8
Brass	0.4...0.5
Aluminum	0.3...0.4
Copper	0.2...0.3

Approximate Dimensions [mm (in.)]

Cable Style

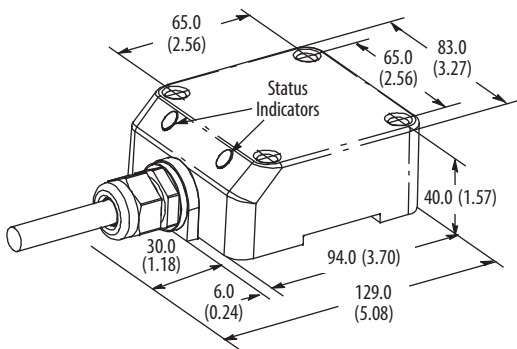

Wiring Diagrams

Normally Open

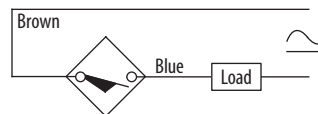

Note: Load can be switched to brown wire.

Approximate Dimensions [mm (in.)]

Mini Style

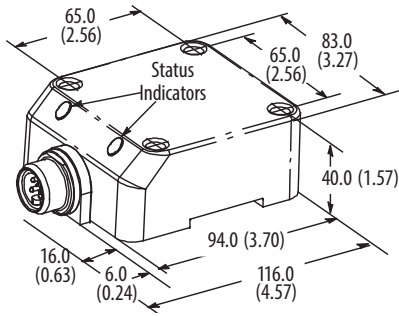

Micro QD Style

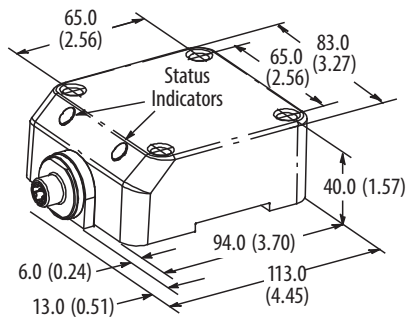

Conduit Style 1/2 in. NPT

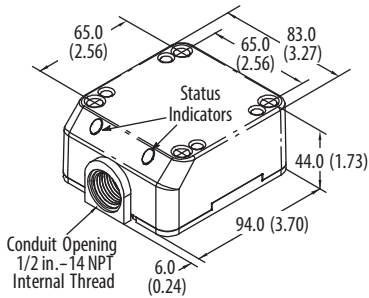

Conduit Style PG13.5

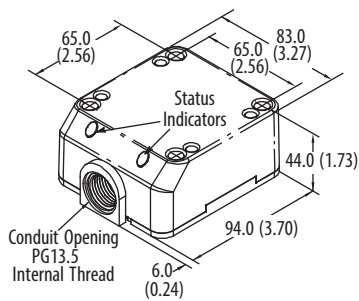

Wiring Diagrams

Normally Open

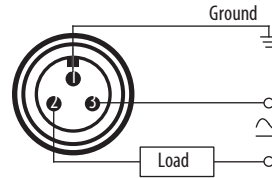

Note: Load can be switched to pin 3

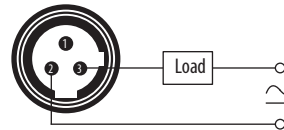

Note: Load can be switched to pin 2

Normally Open

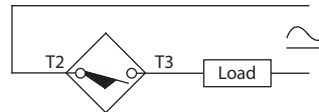

Note: Load can be switched to terminal 2

Normally Open

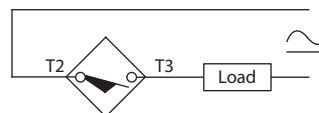

Note: Load can be switched to terminal 2

871F DC Weld Field Immune Rectangular Sensors

Flat Pack Style



871F DC Mini
Quick-disconnect Style



871F DC Micro
Quick-disconnect Style

Specifications

Attribute	871F
Load Current	≤200 mA
Load Current, Min.	1 mA
Leakage Current	≤10 μA
Operating Voltage	10...30V DC
Voltage Drop	≤2.5V
Repeatability	≤5%
Hysteresis	≤5% typical
Protection Type	False pulse, transient noise, reverse polarity, short circuit, and overload Weld Field Immunity 1600 Gauss
Certifications	c-UL-us Listed and CE Marked for all applicable all directives
Enclosure Type Rating	NEMA 1, 2, 3, 4, 6, 6P, 12 and 13; IP67 (IEC529), 1200 psi (8270 kPa) washdown; micro connector versions also meet IP69K (IEC529)
Housing Material	Valox®
Connection Type	Quick Disconnect: 4-pin mini style, 4-pin micro style
Status Indicator	<ul style="list-style-type: none"> • Green: Power • Orange: Output energized
Operating Temperature	-25...+70 °C (-13...+158 °F)
Shock	5 g (0.18 oz)
Vibration	55 Hz, 1 mm amplitude, 3 planes

Correction Factors	
Target Material	Correction Factors
Steel	1.0
Stainless Steel	0.7...0.8
Brass	0.4...0.5
Aluminum	0.3...0.4
Copper	0.2...0.3

Approximate Dimensions [mm (in.)]

Mini QD Style

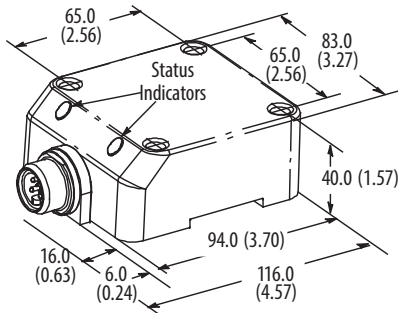

Micro QD Style

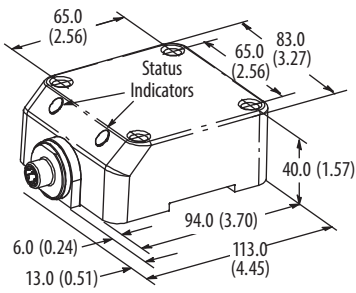

Wiring Diagrams

Complimentary Normally Open and Closed Outputs

PNP (Sourcing)

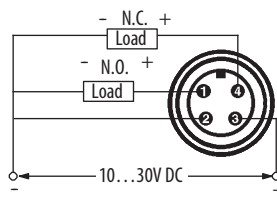

NPN (Sinking)

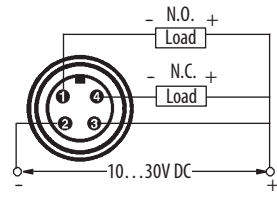

Complimentary Normally Open and Closed Outputs

PNP (Sourcing)

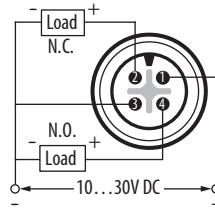

NPN (Sinking)

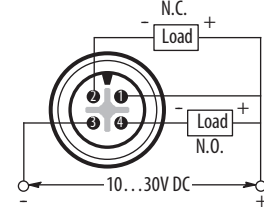

871F 2-wire AC/DC Weld Field Immune Rectangular Sensors

Flat Pack Style



871F AC/DC WFI Micro
Quick-disconnect Style

Specifications

Attribute	871F
Load Current	≤100 mA
Load Current, Min.	5 mA
Leakage Current	≤1.7 mA @ 120V; ≤2.0 mA @ 250V
Operating Voltage	20...250V AC/DC
Voltage Drop	≤10V
Repeatability	≤5%
Hysteresis	10% typical
Protection Type	False pulse, transient noise, short circuit, and overload
Weld Field Immunity	Gauss
Certifications	c-UL-us Listed and CE Marked for all applicable all directives
Enclosure Type Rating	NEMA 1, 2, 3, 4, 6, 6P, 12 and 13; IP67 (IEC529), 1200 psi (8270 kPa) washdown; micro connector versions also meet IP69K (IEC529)
Housing Material	Valox
Connection Type	Quick Disconnect: 3-pin micro style
Status Indicator	<ul style="list-style-type: none"> Green: Power Red: Output energized
Operating Temperature	-25...+70 °C (-13...+158 °F)
Shock	30 g (1.06 oz), 11 ms
Vibration	55 Hz, 1 mm amplitude, 3 planes

Correction Factors

Target Material	Correction Factors	
	Shielded	Unshielded
Steel	1.0	1.0
Stainless Steel	0.7...0.8	0.7...0.8
Brass	0.5...0.6	0.4...0.5
Aluminum	0.4...0.5	0.4...0.5
Copper	0.4...0.5	0.4...0.5

Approximate Dimensions [mm (in.)]

Micro QD Style

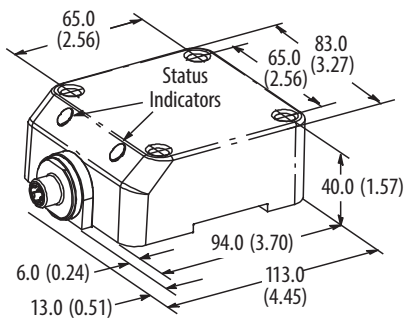

Wiring Diagrams

Normally Open

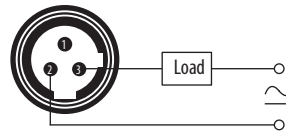

Note: Load can be switched to pin 2

871F 2-wire AC/DC Weld Field Immune Rectangular Sensors

Puck Style



871F AC/DC WFI Mini and Micro Quick-disconnect Style

Specifications

Attribute	871F
Load Current	≤400 mA
Load Current, Min.	3 mA
Inrush Current (one cycle)	≤8 A
Leakage Current	≤1.5 mA
Operating Voltage	20...250V AC/DC
Voltage Drop	≤5V
Repeatability	≤10%
Hysteresis	≤15% typical
Protection Type	Short circuit, false pulse, and transient noise
Weld Field Immunity	20,000 A at 1 inch
Certifications	CE Marked for all applicable directives
Enclosure Type Rating	NEMA 4 and 13, IP67 (IEC529)
Housing Material	Aluminum body, PTFE sensing area
Connection Type	Quick-disconnect: 3-pin mini style, 3-pin micro style
Status Indicator	<ul style="list-style-type: none"> Green: Power Orange: Output energized
Operating Temperature	-25...+70 °C (-13...+158 °F)
Shock	30 g (1.06 oz), 11 ms
Vibration	55 Hz, 1 mm amplitude, 3 planes

Correction Factors

Target Material	Correction Factors
Steel	1.0
Stainless Steel	0.7...0.8
Brass	0.4...0.5
Aluminum	0.3...0.4
Copper	0.2...0.3

Approximate Dimensions [mm (in.)]

Mini QD Style

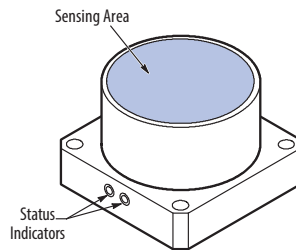
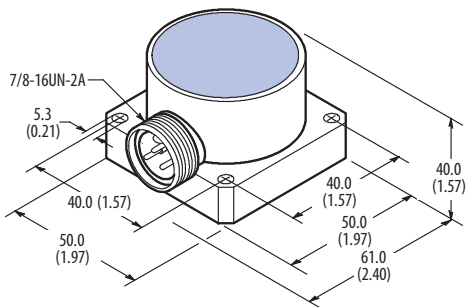

Wiring Diagrams

Normally Open

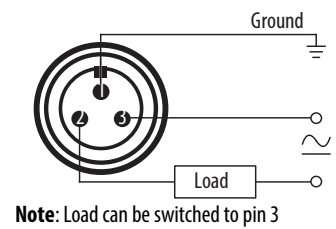

Micro QD Style

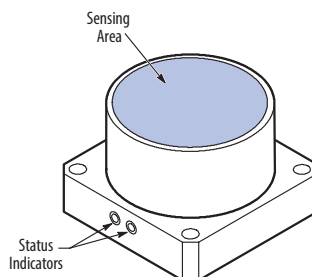
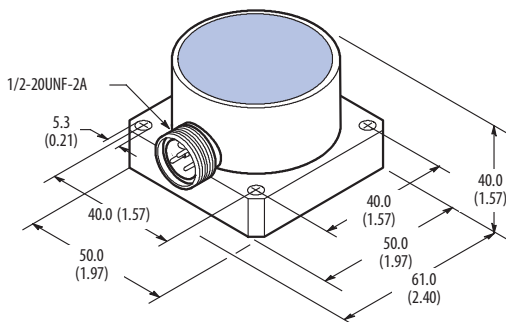

Normally Open

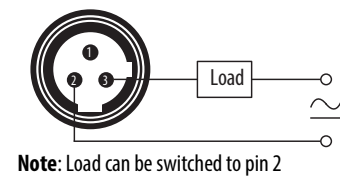

871FM Miniature Metal Flat Pack Sensors

Stainless Steel Face/Stainless Steel Barrel



Specifications

Attribute	General-purpose	Weld Field Immune
Load Current	≤ 100 mA; Auto detect (PNP/NPN) at power-up	
Leakage Current	≤ 10 μA	
Operator Voltage	10...30V	
Voltage Drop	≤ 1.8V	
Switching Frequency	≤ 200 Hz	≤ 50 Hz
Power-On Delay (Time delay before availability)	< 80 ms	
No-Load Supply Current	≤ 30 mA	
Repeatability	≤ 5%	
Hysteresis	5% typical	
Protection Type	False pulse on power, transient noise, reverse polarity, short circuit, and overload	
Certifications	c-UL-us Listed and CE Marked for all applicable directives	
Enclosure Type Rating	IP69K	IP67
Housing Material	Stainless Steel 303 with Stainless Steel face	
Factor-1 equal sensing	Yes	
Connections	203.2 mm (8 in.) pigtail with 4-pin Micro QD	
Operating Temperature	-25...+70 °C (-13...+158 °F)	
Storage Temperature	-40...+70 °C (-40...+158 °F)	
Operating Humidity	5...95% relative (noncondensing)	
Shock	30 g (1.06 oz) with 11 ms pulse duration	
Vibration	55 Hz, 1 mm amplitude	
IO-Link		
Protocol	IO-Link V1.1	
Interface Type	IO-Link	
Mode	COM 2 (38.4 kBd)	
Cycle Time	10.4 ms, minimum	
SIO (standard I/O)	Supported (pin 4 for either IO-Link or SIO)	

Nominal Sensing Distance

Housing Size	General-purpose	
20 x 32 x 8 mm (0.79 x 1.26 x 0.31 in.)	7 mm (0.27 in.)	For weld field immune units, the thickness of the weld slag coating on the sensor face (approximately 0.5 mm [0.02 in.]) reduces the nominal range
30 x 52 x 14 mm (1.18 x 2.05 x 0.55 in.)	10 mm (0.39 in.)	

Status Indication

Green Indicator (Power)	Orange Indicator (Output)	Condition
Off	Off	Power Off
On	Off	Powered On/No Target
Off	On	Target Present
Off	Flash at 2.0 Hz	Passed On Point (Margin Zone)
Flash at 2.0 Hz	Off	Short Circuit, Fault
Flash at 2.0 Hz	Flash at 2.0 Hz; Reverse from Green Status Indicator	Location Indication Mode

Dimensions [mm (in.)]

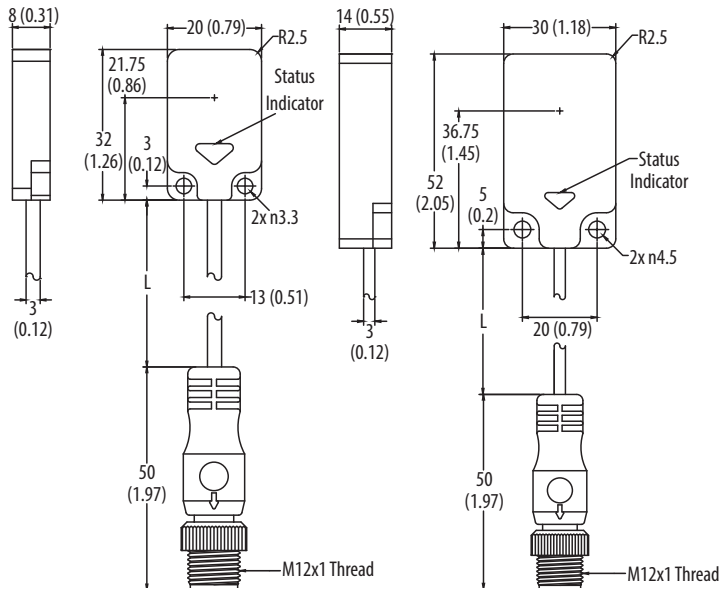

20 (W) x 32 (L) x 8 (H)	A	B	C	D	E
7 mm Sensing	24 (0.94)	35 (1.38)	20 (0.79)	20 (0.79)	48 (1.89)
30 (W) x 52 (L) x 14 (H)					
10 mm Sensing	45 (1.77)	45 (0.79)	30 (1.18)	30 (1.18)	90 (3.54)

Mounting

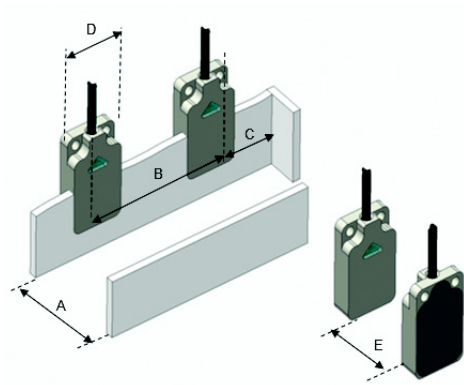

Wiring [mm (in.)]

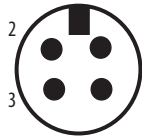
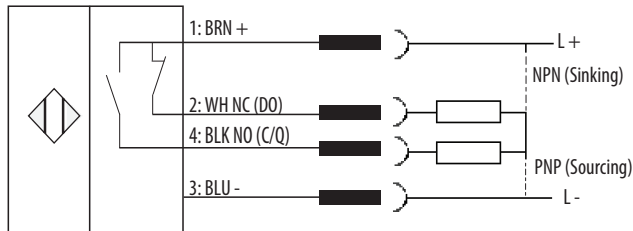

Cable Material	Standard Model: PVC Weld Tube Model: PUR
Cable Diameter	Standard: 3.05 mm (0.12 in.) Weld Tube: 6 mm (0.24 in.)
Wire Gauge	26 AWG, 0.75 mm (0.03 in.), 4 conductor

Dimension	Nominal Sensing Distance	Shielded	Output Configuration	Switching Frequency [Hz]	Weld Field Immune	Connector Type
20 (W) x 32 (L) x 8 (H)	7 (0.27)	Yes	Complementary N.O./N.C.	≤200	No	0.2 m (0.66 ft) PVC pigtail, DC micro QD, 4-pin
				≤200	No	PVC cable, 2 m (6.56 ft)
				≤50	Yes - ToughCoat Finish™	0.2 m (0.66 ft) PVC pigtail, DC micro QD, 4-pin
30 (W) x 52 (L) x 14 (H)	10 (0.39)			≤200	No	0.2 m (0.66 ft) PVC pigtail, DC micro QD, 4-pin
				≤200	No	PVC cable, 2 m (6.56 ft)
				≤50	Yes - ToughCoat Finish	0.2 m (0.66 ft) PVC pigtail, DC micro QD, 4-pin

871FM 3-wire DC Rectangular Sensors

Miniature Flat Pack Style—Plastic Housing

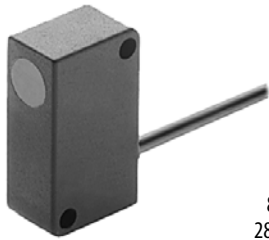

871 FM DC Cable Style
28 mm x 16 mm x 11 mm

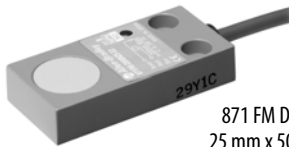

871 FM DC Cable Style
25 mm x 50 mm x 10 mm



871FM DC Cable Style
30 x 18 x 10 mm



871FM DC Pico
Quick-disconnect Style
28 x 16 x 11 mm

Specifications

Attribute	28 mm x 16 mm x 11 mm	25 mm x 50 mm x 10 mm	31 mm x 18 mm x 10 mm
Current Consumption	<11 mA	<8 mA	10 mA
Load Current	≤200 mA	≤200 mA	50 mA @ 12V DC 100 mA @ 24V DC
Leakage Current	≤100 μA	≤100 μA	≤100 μA
Operating Voltage	10...30V DC	10...24V DC	10...30V DC
Voltage Drop	≤1.8V	≤2.5V	≤1V
Repeatability	≤5%		
Hysteresis	10% typical		
Protection Type	False pulse, transient noise, reverse polarity, short circuit, and overload		
Certifications	CE Marked for all applicable directives		
Enclosure Type Rating	NEMA 4; IP67 (IEC 529)		
Housing Material	Plastic		
Connection Type	<ul style="list-style-type: none"> Cable: 2 m (6.5 ft) length, 3-conductor PVC Quick-disconnect: 3-pin pico style 		
Status Indicator	Yellow: Output energized Red: Output energized		
Operating Temperature	-25...+70 °C (-13...+158 °F)		
Shock	30 g (1.06 oz), 11 ms		50 g (1.76 oz) (approximate)
Vibration	55 Hz, 1 mm (0.039 in.) amplitude, 3 planes		10...55Hz @ 1...5 mm (0.039...0.2 in.)

Correction Factors

Target Material	Correction Factors
Steel	1.0
Stainless Steel	0.85
Brass	0.55
Aluminum	0.5
Copper	0.45

Approximate Dimensions [mm (in.)]

Cable and Pico QD Style (28 x 16 x 11 mm)

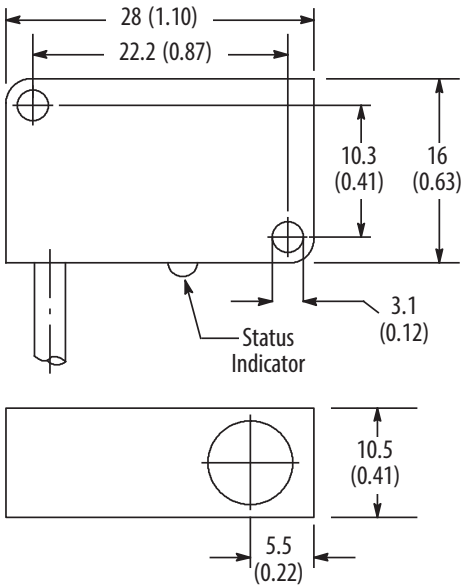

Unshielded Cable, Pico QD, and Shielded Pico QD Style (25 x 50 x 10 mm)

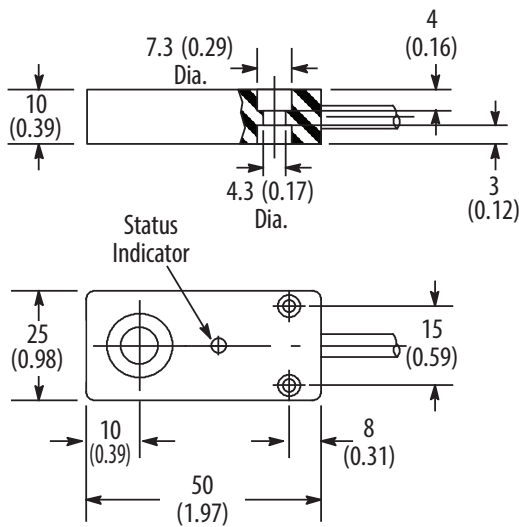

Wiring Diagrams

Cable Style (28 x 16 x 11 mm)

Normally Open

NPN (Sinking)

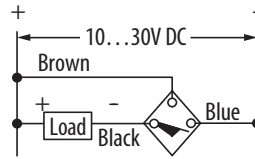

PNP (Sourcing)

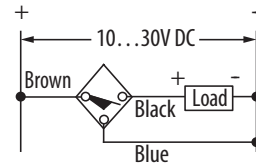

Pico QD Style (28 x 16 x 11 mm)

Normally Closed

PNP (Sourcing)

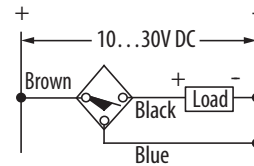

Pico QD Style (28 x 16 x 11 mm)

Normally Open or Normally Closed

NPN (Sinking)

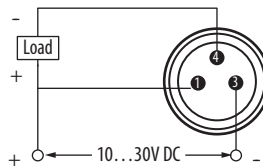

PNP (Sourcing)

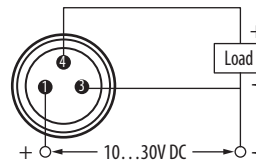

Style 25 x 50 x 10 mm

Normally Open

NPN (Sinking)

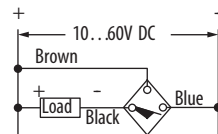

PNP (Sourcing)

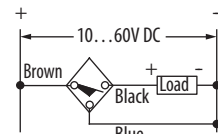

Normally Closed

NPN (Sinking)

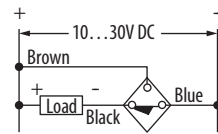

PNP (Sourcing)

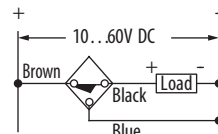

Approximate Dimensions [mm (in.)]

Shielded Cable Style (25 X 50 X 10 mm)

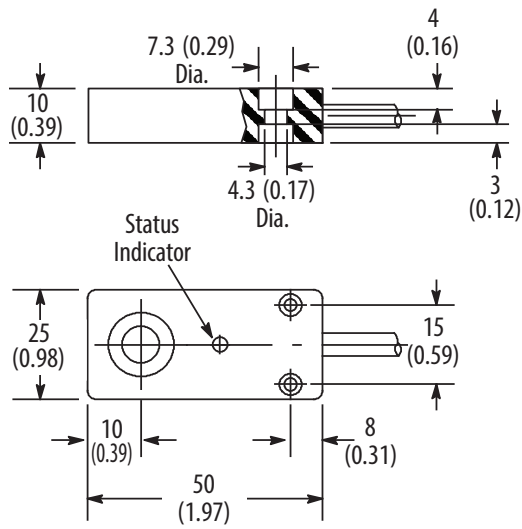

Wiring Diagrams

Cable Style (25 X 50 X 10 mm)

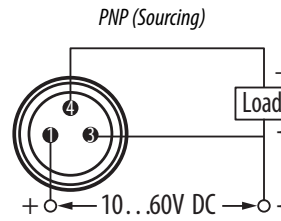

Cable Style (31 X 18 X 10 mm)

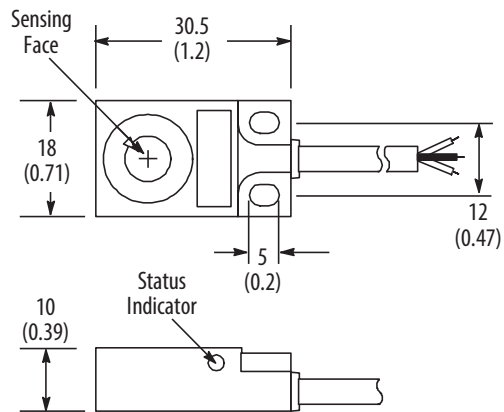

Cable Style (31 X 18 X 10 mm)

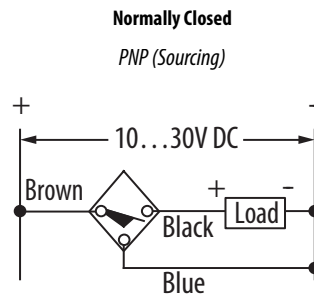

871FM 3-wire DC Rectangular Sensors

Miniature Flat Pack Style—Metal Housing



871FM DC Pico
MS Square



871FM DC Cable
MS Square



Specifications

Attribute	871FM
Certifications	UL Listed and CE Marked for all applicable directives
Environmental	
Operating Environment	IP67 (IEC 529)
Operating Temperature	-25...+70 °C (-13...+158 °F)
Vibration	10...55 Hz, 1 mm amplitude, 3 planes
Shock	30 g (1.06 oz), 11 ms
Electrical	
Load Current	≤200 mA
Leakage Current	0.1 mA
Operating Voltage	10...30V DC
Voltage Drop	2.4V
Repeatability	10%
Hysteresis	12% typical
Protection Type	False pulse, transient noise, reverse polarity, and short circuit
IO-Link	
Protocol	O-Link V1.0
Interface Type	IO-Link
Mode	COM 2 (38.4 kBd)
Cycle Time	10.4 ms, minimum
SIO (standard I/O)	Supported (pin 4 for either IO-Link or SIO)
Mechanical	
Housing Material	Nickel-plated brass, polyester face
Status Indicator (SIO mode)	Yellow: Output energized
Status Indicator (IO-Link Mode)	Solid yellow: Sensor in IO-Link mode
Connection Type	Cable, pico QD, or pico with lead

Correction Factors

Sensor Type/Target Material (No Surrounding Metal)	M5 Square		M8 Square	
	Shielded	Unshielded	Shielded	Unshielded
Steel	1	1	1	1
Copper	0.6	0.6	0.45	0.27
Aluminum	0.6	0.6	0.5	0.36
Brass	0.7	0.7	0.6	0.45
Stainless Steel 304	0.85	0.85	0.8	0.77

Switching Frequency

Head Size	Nominal Sensing Distance [mm (in.)]	Switching Frequency [Hz]
5 mm	0.8 (0.03)	5000
	1.5 (0.06)	3000
8 mm	2.0 (0.08)	
	3.0 (.12)	1000

Approximate Dimensions [mm (in.)]

M5 and M8 Square Cable

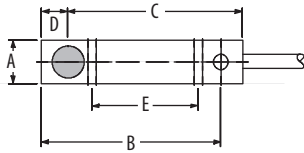

Wiring Diagrams

Normally Open

NPN (Sinking)

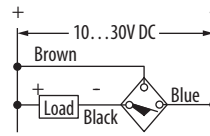

PNP (Sourcing)

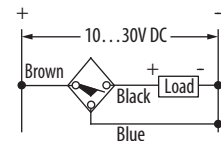

M5 Square with 6 inch Lead

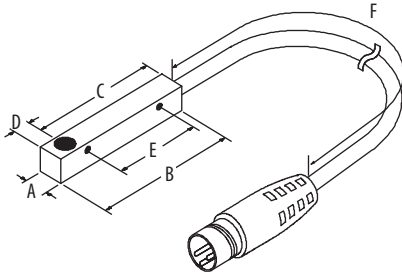

Normally Open

NPN (Sinking)

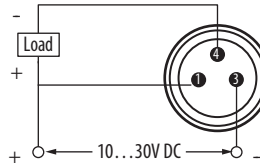

PNP (Sourcing)

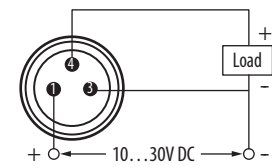

M8 Square 3-Pin Pico

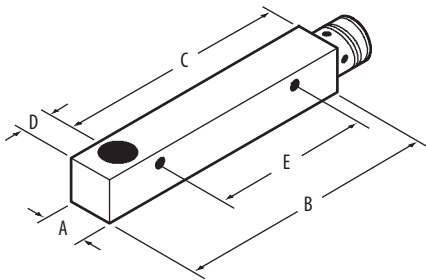

Normally Open

NPN (Sinking)

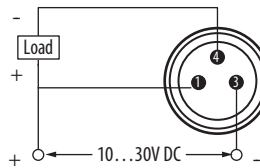

PNP (Sourcing)

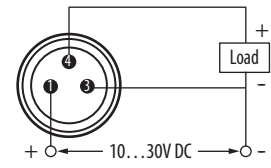

871L and 872L 3-wire DC Rectangular Sensors

Limit Switch Style



871L and 872L DC
Mini Quick-disconnect Style



871L and 872L DC
Micro Quick-disconnect Style



871L and 872L DC
Conduit Style

Specifications

Attribute	871L Models	872L Models
Load Current	≤400 mA	≤200 mA
Leakage Current	≤10 µA	
Operating Voltage	10...60V DC	10...30V DC
Voltage Drop	≤2.4V	≤2.5V
Repeatability	≤5%	
Hysteresis	≤20% typical	
Protection Type	False pulse, transient noise, reverse polarity, short circuit, and overload	
Certifications	c-UL-us Listed and CE Marked for all applicable directives	
Enclosure Type Rating	NEMA 3, 4, 6, 12, 13; IP67 (IEC 529)	
Housing Material	Polyloy™	
Connection Type	<ul style="list-style-type: none"> Quick-disconnect: 4-pin mini, 4-pin micro Conduit Opening: 1/2-14 NPT internal thread with screw terminals 	
Indicator Status Indicators	<ul style="list-style-type: none"> Green: Power (blinks in SCP/overload), Orange: Output energized, Red: Alignment indicator 	<ul style="list-style-type: none"> Green: Power (blinks in SCP/overload) Orange: Output energized
Operating Temperature	-25...+70 °C (-13...+158 °F)	
Shock	30 g (1.06 oz), 11 ms	
Vibration	55 Hz, 1 mm amplitude, 3 planes	

Correction Factors

Target Material	Correction Factor
Steel	1.0
Stainless Steel	0.7...0.8
Brass	0.4...0.5
Aluminum	0.3...0.4
Copper	0.2...0.3

Approximate Dimensions [mm (in.)]

Conduit Style

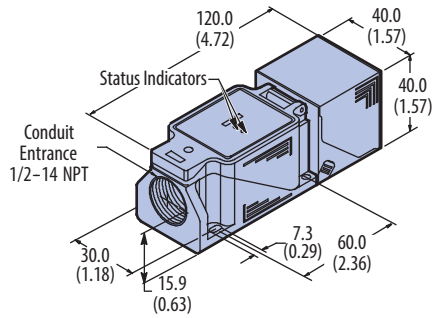

Note: Head can be rotated in 22.5° increments to provide 16 side-sensing positions or rotated for top-sensing.

Mini QD Style

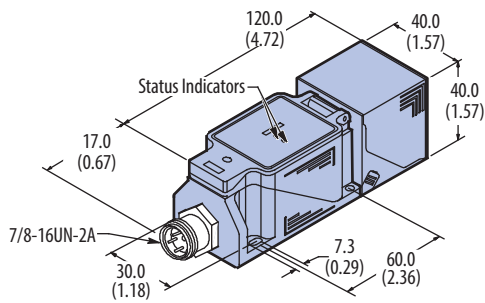

Note: Head can be rotated in 22.5° increments to provide 16 side-sensing positions or rotated for top-sensing.

Micro QD Style

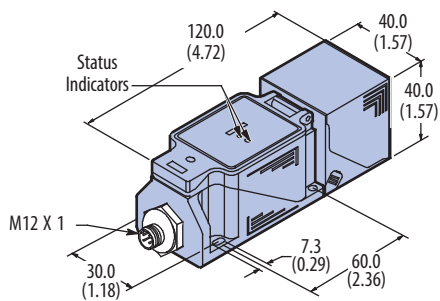

Wiring Diagrams

Normally Open

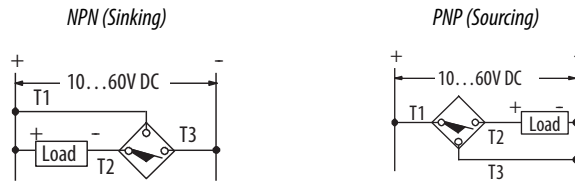

Normally Closed

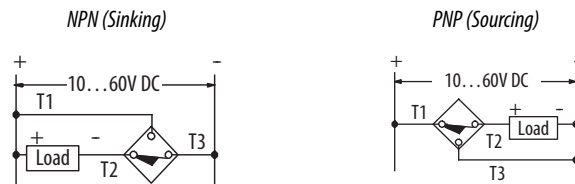

Normally Open or Normally Closed

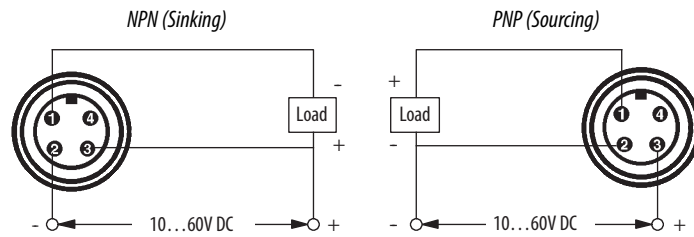

Normally Open or Normally Closed

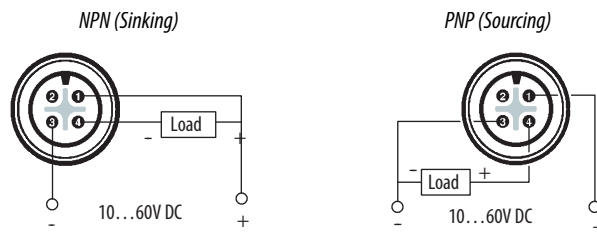

871L AC/DC and 872L AC 2-wire Rectangular Sensors

Limit Switch Style



871L and 872L DC
Mini Quick-disconnect Style



871L and 872L DC
Micro Quick-disconnect Style



871L and 872L DC
Conduit Style

Specifications

Attribute	871L Models	872L Models
Load Current	≤400 mA	≤500 mA
Load Current, Min.	2 mA	
Inrush Current (one cycle)	≤8 A	
Leakage Current	≤2 mA	
Operating Voltage	20...250V AC/DC	20...250V AC
Voltage Drop	≤5V	
Repeatability	≤5%	
Hysteresis	≤20%	
Protection Type	False pulse and transient noise	
Certifications	c-UL-us Listed and CE Marked for all applicable directives	
Enclosure Type Rating	NEMA 3, 4, 6, 12, 13; IP65 (IEC 529)	
Housing Material	Polyloy	
Connection Type	<ul style="list-style-type: none"> Quick Disconnect: 3-pin mini style, 3-pin micro style Conduit Opening: 1/2-14 NPT internal thread with screw terminals 	
Indicator Status Indicators	<ul style="list-style-type: none"> Green: Power (blinks in SCP/overload) Orange: Output energized 	
Operating Temperature	-25...+70 °C (-13...+158 °F)	
Shock	30 g (1.06 oz), 11 ms	
Vibration	55 Hz, 1 mm amplitude, 3 planes	

Correction Factors

Target Material	Correction Factor
Steel	1.0
Stainless Steel	0.7...0.8
Brass	0.4...0.5
Aluminum	0.3...0.4
Copper	0.2...0.3

Approximate Dimensions [mm (in.)]

Conduit Style

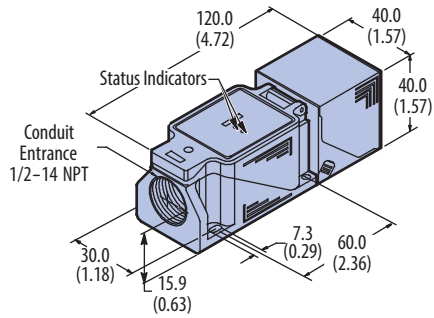

Note: Head can be rotated in 22.5° increments to provide 16 side-sensing positions or rotated for top-sensing.

Mini QD Style

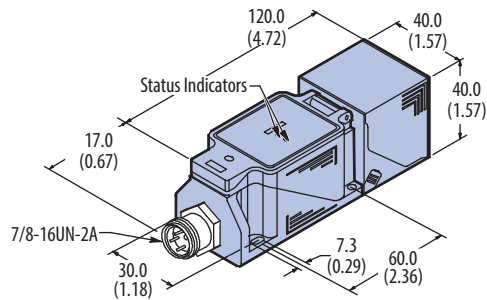

Note: Head can be rotated in 22.5° increments to provide 16 side-sensing positions or rotated for top-sensing.

Micro QD Style

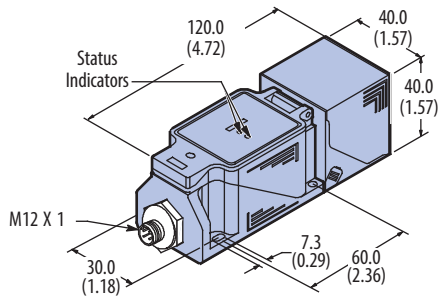

Wiring Diagrams

Normally Open

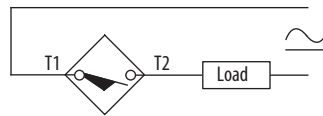

Note: Load can be switched to terminal 1.

Normally Closed

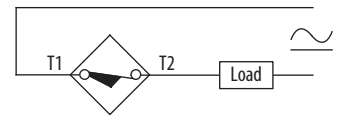

Note: Load can be switched to terminal 1.

Normally Open or Normally Closed

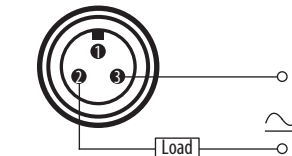

Note: Load can be switched to pin 3.

Normally Open or Normally Closed

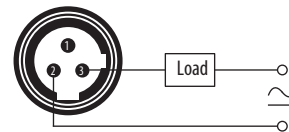

Note: Load can be switched to pin 2.

871P 2-wire AC Rectangular Sensors

Can Sensors



871P AC Long Range
76 X 36 X 58 mm

Specifications

Attribute	871P
Load Current, Max.	300 mA
Load Current, Min.	15 mA
Leakage Current	<1.5 mA
Inrush Current	<5 A (20 ms)
Operating Voltage	30...150V AC RMS
Line Frequency	40...60 Hz
Voltage Drop	<15V @ 300 mA
Repeatability	≤2%
Hysteresis	10% typical
Protection Type	False pulse, transient noise, short circuit, and overload
Certifications	UL Listed and CE Marked for all applicable directives
Enclosure Type Rating	NEMA 1, 3, 4, 4X, 6, 6P, 12, 13; IP67 (IEC 529), 1200 psi (8270 kPa) washdown
Connection Type	3-pin mini style
Status Indicator	Red: Output Energized
Operating Temperature	-20...+70 °C (0...160 °F)

Approximate Dimensions [mm (in.)]

Long-Range Mini QD Style

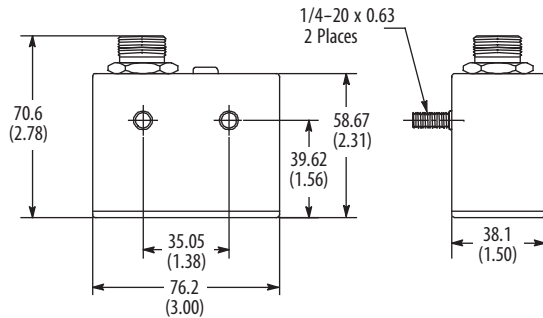

Wiring Diagrams

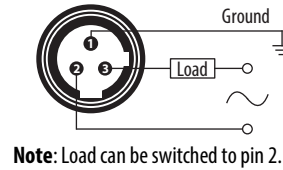

871P 4-wire DC Rectangular Sensors

Can Sensors

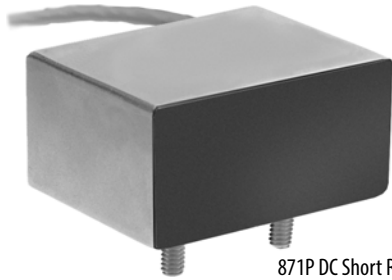

871P DC Short Range
76 X 36 58 mm

Specifications

Attribute	871P
Load Current	300 mA
Operating Voltage	10...30V DC
Operating Current	25 mA (off), 55 mA (on)
Voltage Drop	≤2.5V
Repeatability	≤2%
Hysteresis	3...15%
Protection Type	False pulse, transient noise, short circuit, overload, and reverse polarity
Enclosure Type Rating	NEMA 1, 3, 4, 4X, 6, 6P, 12, 13; IP67 (IEC 529), 1200 psi (8270 kPa) washdown
Connection Type	<ul style="list-style-type: none"> A2: 2 m (6.6 ft) shielded PVC jacketed cable, 4-wire, #22 AWG, 1/2 in. NPT N4: 4-pin mini quick-disconnect
Status Indicator	Red: Output energized
Operating Temperature	-20...+70 °C (0...160 °F)
Housing Material	Stainless steel, plastic face
Mounting	Two stainless steel studs

Approximate Dimensions [mm (in.)]

Conduit Style

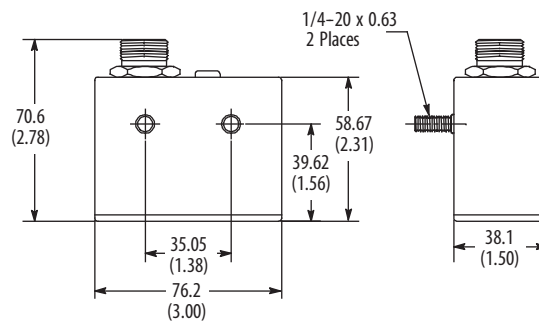

Long Range Cable Style

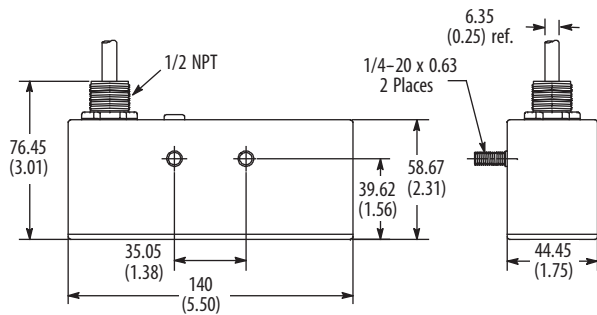

Long Range Mini QD Style

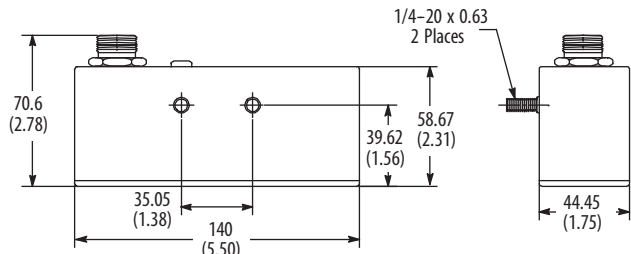

Cable Style

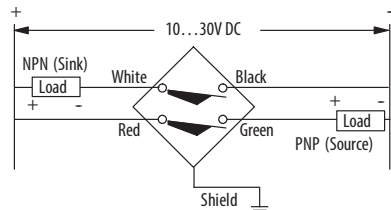

Mini QD Style

Note: Red and black wires must be connected for proper operation.

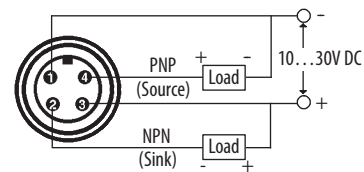

871P 4-wire DC Motion Rectangular Sensors

Can Sensors

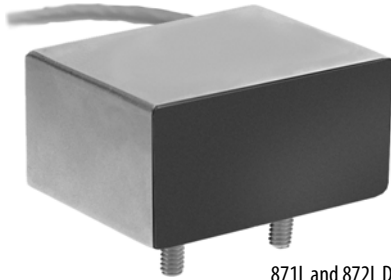

871L and 872L DC
Mini Quick-disconnect Style

Specifications

Attribute	871P
Load Current	300 mA
Operating Voltage	10...30V DC
Operating Current	25 mA (off), 55 mA (on)
Voltage Drop	≤2.5V
Repeatability	≤2%
Hysteresis	3...15%
Output Time Delay	0.5 s after motion stops
Protection Type	False pulse, transient noise, short circuit, overload, and reverse polarity
Enclosure Type Rating	NEMA 1, 3, 4, 4X, 6, 6P, 12, 13; IP67 (IEC 529), 1200 psi (8270 kPa) washdown
Connection Type	<ul style="list-style-type: none"> A2: 2 m (6.6 ft) shielded PVC jacketed cable, 4-wire, #22 AWG, 1/2 in. NPT N4: 4-pin mini quick-disconnect D4: 4-pin micro quick-disconnect
Status Indicator	<ul style="list-style-type: none"> Red: Output energized Dim Blink: Cans moving Bright Steady: No motion
Sensitivity Adjustment	Sensing range adjust
Operating Temperature	-20...+70 °C (0...160 °F)
Housing Material	Stainless steel, plastic face
Mounting	Two stainless steel studs

Approximate Dimensions [mm (in.)]

Cable Style

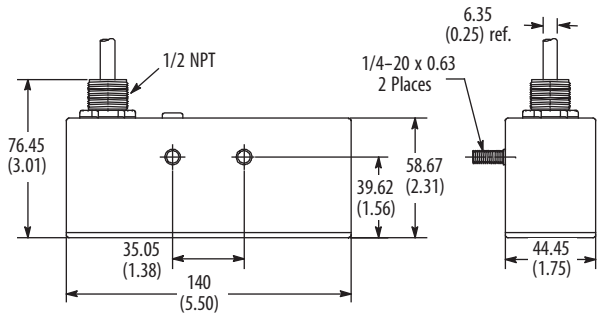

Wiring Diagrams

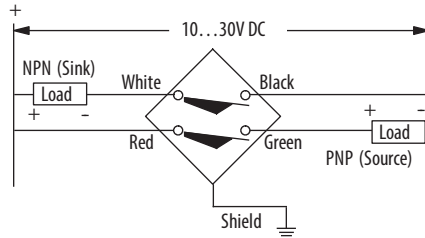

Mini and Micro QD Style

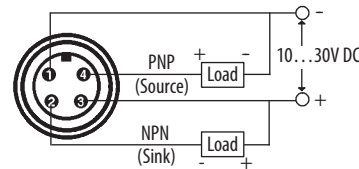
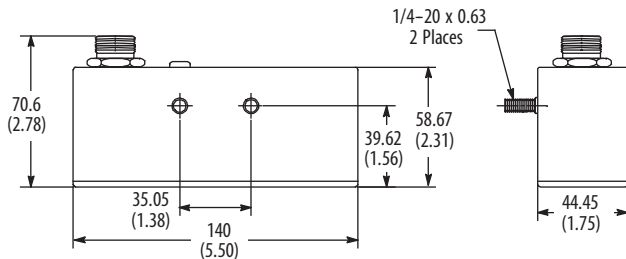

871P 4-wire DC Motion Rectangular Sensors

Can Sensors



871L and 872L DC
Mini Quick-disconnect Style

Specifications

Attribute	871P
Load Current	300 mA
Operating Voltage	10...30V DC
Operating Current	25 mA (off), 55 mA (on)
Voltage Drop	≤2.5V
Repeatability	≤2%
Hysteresis	3...15%
Output Time Delay	0.5 s after motion stops
Protection Type	False pulse, transient noise, short circuit, overload, and reverse polarity
Enclosure Type Rating	NEMA 1, 3, 4, 4X, 6, 6P, 12, 13; IP67 (IEC 529), 1200 psi (8270 kPa) washdown
Connection Type	<ul style="list-style-type: none"> A2: 2 m (6.6 ft) shielded PVC jacketed cable, 4-wire, #22 AWG, 1/2 in. NPT N4: 4-pin mini quick-disconnect D4: 4-pin micro quick-disconnect
Status Indicator	<ul style="list-style-type: none"> Red: Output energized Dim Blink: Cans moving Bright Steady: No motion
Sensitivity Adjustment	Sensing range adjust
Operating Temperature	-20...+70 °C (0...160 °F)
Housing Material	Stainless steel, plastic face
Mounting	2 stainless steel studs

Approximate Dimensions [mm (in.)]

Cable Style

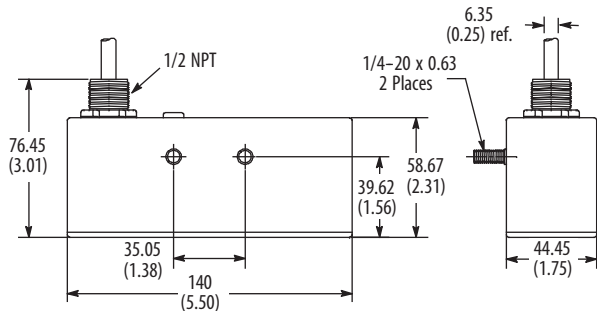

Mini and Micro QD Style

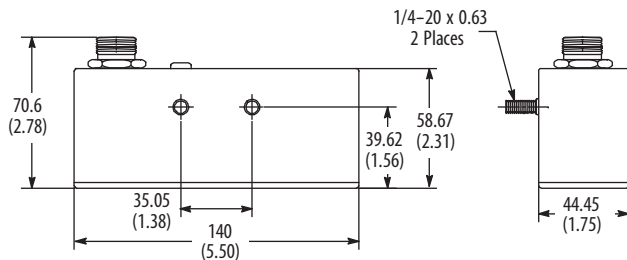

Wiring Diagrams

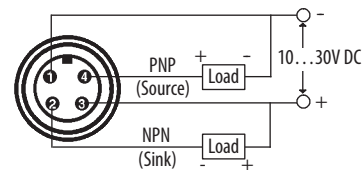
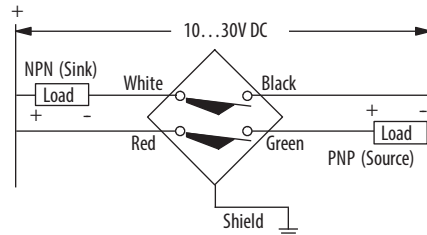

871P VersaCube® 3-wire DC Rectangular Sensors

General-purpose



871P DC Micro
Quick-disconnect Style



871P DC Mini
Quick-disconnect Style

Specifications

Attribute	871P
Load Current	≤200 mA
Leakage Current	≤10 µA
Operating Voltage	10...60V DC
Voltage Drop	<2.5V @ 200 mA
Repeatability	≤5%
Hysteresis	5% typical
Protection Type	False pulse, transient noise, short circuit, overload, and reverse polarity
Certifications	c-UL-us Listed and CE Marked for all applicable directives
Enclosure Type Rating	NEMA 1, 2, 3, 4, 6, 6P, 12, 13; IP67 (IEC 529), 1200 psi (8270 kPa) washdown; micro connector versions also meet IP69K (IEC 529)
Housing Material	<ul style="list-style-type: none"> • Body: Plastic • Base: Zinc
Connection Type	Quick disconnect: 4-pin mini style, 4-pin micro style
Indicator Status Indicators	<ul style="list-style-type: none"> • Orange: Output energized • Green: Power
Operating Temperature	-25...+70 °C (-13...+158 °F)
Shock	30 g (1.06 oz), 11 ms
Vibration	55 Hz, 1 mm amplitude, 3 planes

Correction Factors

Target Material	Correction Factor
Steel	1.0
Stainless Steel	0.7...0.8
Brass	0.4...0.5
Aluminum	0.3...0.4
Copper	0.2...0.3

Approximate Dimensions [mm (in.)]

Cable Style

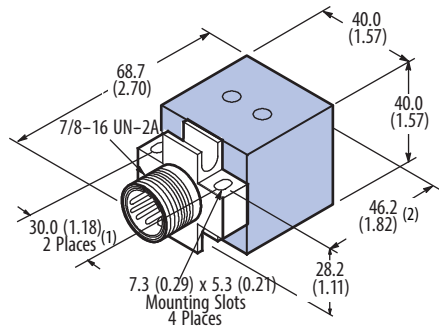

- (1) With retrofit adapter, spacing between mounting holes becomes 20.0 (0.79).
- (2) With retrofit adapter, distance from face to mounting holes becomes 60.0 (2.36).

Mini and Micro QD Style

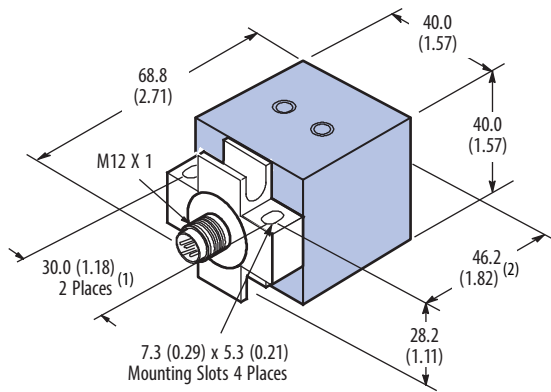

- (1) With retrofit adapter, spacing between mounting holes becomes 20.0 (0.79).
- (2) With retrofit adapter, distance from face to mounting holes becomes 60.0 (2.36).

Wiring Diagrams

Normally Open or Normally Closed

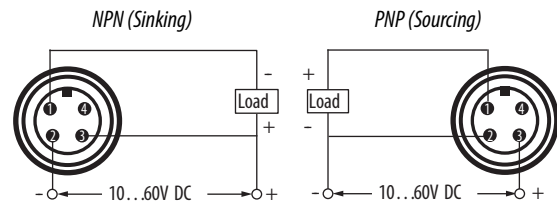

Normally Open or Normally Closed

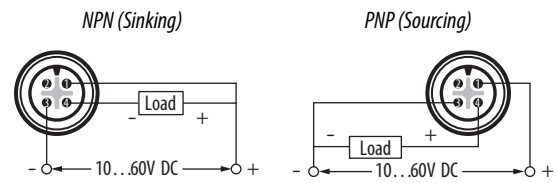

ATTENTION: Unit must be mounted to a grounded metal frame or grounded via field wiring lug per NEC requirements. Recommended grounding lug is included with the mounting kit (catalog number 871A-PKIT).

871P VersaCube 4-wire DC Rectangular Sensors

General-purpose



871P DC Micro
Mini Quick-disconnect Style
(Standard Zinc Mounting Bracket)



871P DC Micro DC
Mini Quick-disconnect Style
(Optional Stainless-steel Mounting L-Bracket)

Specifications

Attribute	871P
Load Current	≤200 mA from -25...+50 °C (-13...+122 °F) ≤100 mA from 50...70 °C (122...158 °F)
Leakage Current	≤10 µA
Operating Voltage	10...30V DC
Voltage Drop	<2.5V @ 200 mA
Repeatability	≤10%
Hysteresis	10% typical
Protection Type	False pulse, transient noise, short circuit, overload, and reverse polarity
Weld Field Immunity	1000 Gauss
Certifications	c-UL-us Listed and CE Marked for all applicable directives
Enclosure Type Rating	NEMA 1, 2, 3, 4, 6, 6P, 12, 13; IP67 (IEC 529), IP68, IP69k, 1200 psi (8270 kPa) washdown; Plastic body, zinc bracket, optional stainless steel L-bracket
Connection Type	Quick Disconnect: 4-pin micro style
Indicator Status Indicators	<ul style="list-style-type: none"> • Power: Green • Output that is energized: Amber • Margin indication: Amber flashing (target within 80...100% of operating distance) • Short circuit or overload: Green and amber flashing
Operating Temperature	-25...+70 °C (-13...+158 °F)
Shock	30 g (1.06 oz), 11 ms
Vibration	55 Hz, 1 mm amplitude, 3 planes

Correction Factors

Target Material	Correction Factor
Steel	1.0
Stainless Steel	1.0
Brass	1.0
Aluminum	1.0
Copper	1.0

IMPORTANT The 871P VersaCube® is offered with ToughCoat Finish on the sensor face. This finish is a proprietary epoxy-based material that resists the adhesion and accumulation of weld-slag particles, which improves and extends sensor performance.

Approximate Dimensions [mm (in.)]

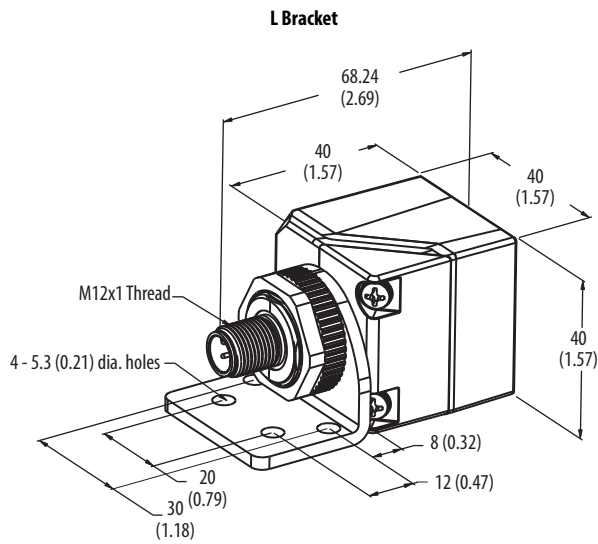
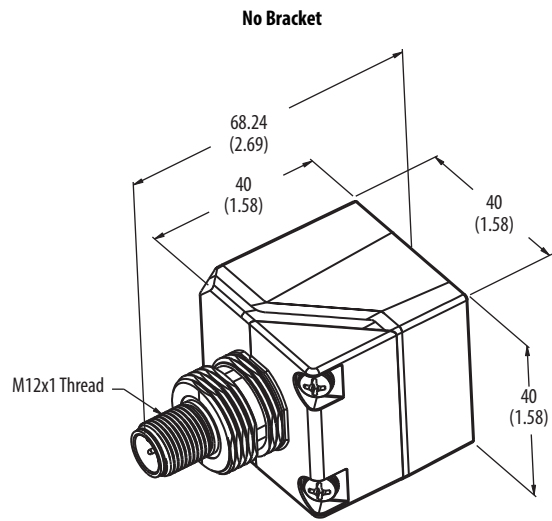
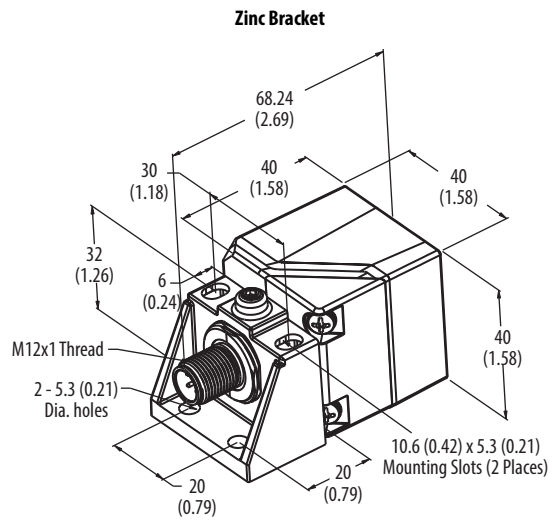

Wiring Diagrams Micro QD Style

Complimentary Normally Open and Normally Closed

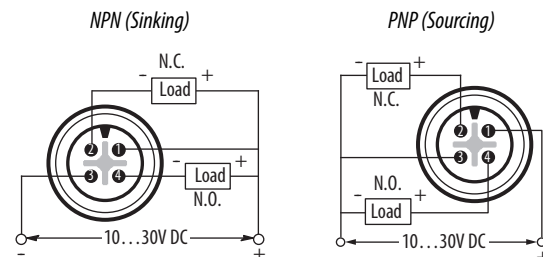

871P VersaCube 2-wire DC Rectangular Sensors

General-purpose

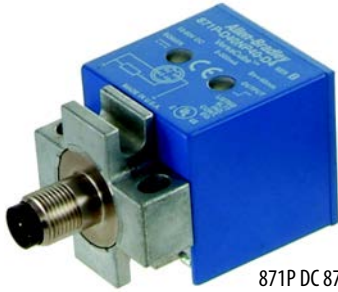

871P DC 872L DC Micro Quick-disconnect Style

Specifications

Attribute	871P
Load Current	2...100 mA
Inrush Current	≤2 A
Leakage Current	≤1.5 mA @ 20V, ≤1.7 mA @ 120V, ≤2.0 mA @ 250V
Operating Voltage	20...250V AC/DC
Voltage Drop	<10V
Repeatability	≤10% of effective operating distance
Hysteresis	12% typical
Protection Type	False pulse, transient noise, short circuit, and overload
Certifications	c-UL-us Listed and CE Marked for all applicable directives
Enclosure Type Rating	NEMA 1, 2, 3, 4, 6, 6P, 12, 13; IP67 (IEC 529), 1200 psi (8270 kPa) washdown; micro connector versions also meet IP69K (IEC 529)
Housing Material	Plastic body, zinc base
Connection Type	Quick Disconnect: 3-pin mini style, 3-pin micro style
Indicator Status Indicators	<ul style="list-style-type: none"> • Red: Output energized • Green: Power (short circuit if flashing)
Operating Temperature	-25...+70 °C (-13...+158 °F)
Shock	30 g (1.06 oz), 11 ms
Vibration	55 Hz, 1 mm amplitude, 3 planes

Correction Factor

Target Material	Correction Factor
Steel	1.0
Stainless Steel	0.7...0.8
Brass	0.4...0.5
Aluminum	0.3...0.4
Copper	0.2...0.3

Approximate Dimensions [mm (in.)]

Mini QD Style

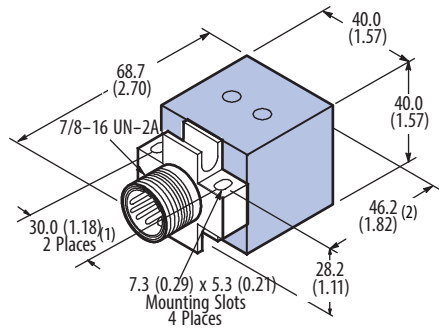

- (1) With retrofit adapter, spacing between mounting holes becomes 20.0 (0.79).
- (2) With retrofit adapter, distance from face to mounting holes becomes 60.0 (2.36).

Micro QD Style

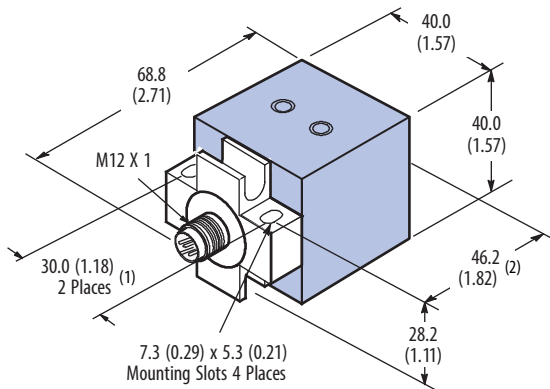

- (1) With retrofit adapter, spacing between mounting holes becomes 20.0 (0.79).
- (2) With retrofit adapter, distance from face to mounting holes becomes 60.0 (2.36).

Wiring Diagrams

Normally Open or Normally Closed

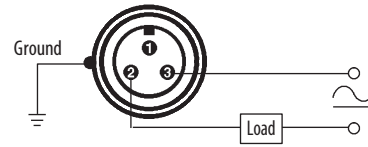

Note: Load can be switched to pin 3.

Normally Open or Normally Closed

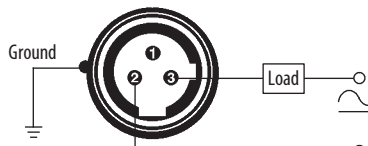

Note: Load can be switched to pin 2.



ATTENTION: Unit must be mounted to a grounded metal frame or grounded via field wiring lug per NEC requirements. Recommended grounding lug is included with the mounting kit (catalog number 871A-PKIT).

871P VersaCube 3-wire DC Rectangular Sensors

Weld Field Immune and ToughCoat Finish



871P DC 872L DC Micro
Quick-disconnect Style



871P DC Mini
Quick-disconnect Style

Specifications

Attribute	871P
Load Current	≤200 mA
Leakage Current	≤10 μA
Operating Voltage	10...60V DC
Voltage Drop	<2.5V @ 200 mA
Repeatability	≤10% of effective operating distance
Hysteresis	12% typical
Protection Type	False pulse, transient noise, short circuit, overload, and reverse polarity
Weld Field Immunity	1000 Gauss
Certifications	UL Listed, c-UL Certified, and CE Marked for all applicable directives
Enclosure Type Rating	NEMA 1, 2, 3, 4, 6, 6P, 12, 13; IP67 (IEC 529), 1200 psi (8270 kPa) washdown; micro connector versions also meet IP69K (IEC 529)
Housing Material	Plastic body, zinc base
Connection Type	Quick Disconnect: 4-pin mini style, 4-pin micro style
Indicator Status Indicators	<ul style="list-style-type: none"> • Orange: Output energized • Green: Power
Operating Temperature	-25...+70 °C (-13...+158 °F)
Shock	30 g (1.06 oz), 11 ms
Vibration	55 Hz, 1 mm amplitude, 3 planes

Correction Factor

Target Material	Correction Factor
Steel	1.0
Stainless Steel	0.7...0.8
Brass	0.4...0.5
Aluminum	0.3...0.4
Copper	0.2...0.3

Approximate Dimensions [mm (in.)]

Mini QD Style

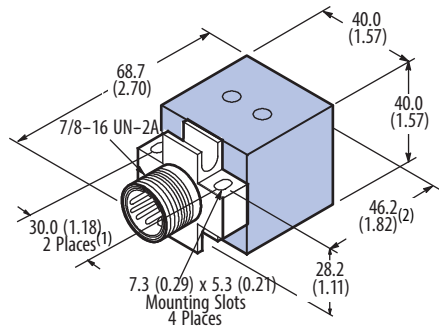

- (1) With retrofit adapter, spacing between mounting holes becomes 20.0 (0.79).
- (2) With retrofit adapter, distance from face to mounting holes becomes 60.0 (2.36).

Micro QD Style

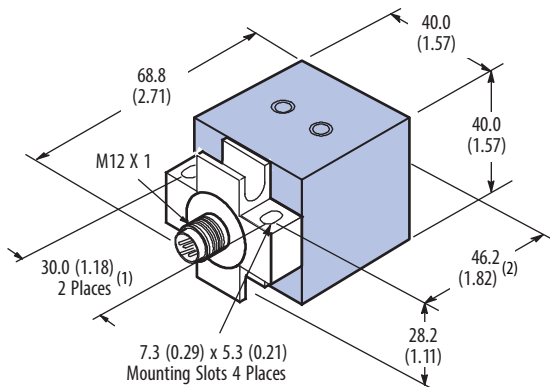

- (1) With retrofit adapter, spacing between mounting holes becomes 20.0 (0.79).
- (2) With retrofit adapter, distance from face to mounting holes becomes 60.0 (2.36).

Wiring Diagrams

Normally Open or Normally Closed

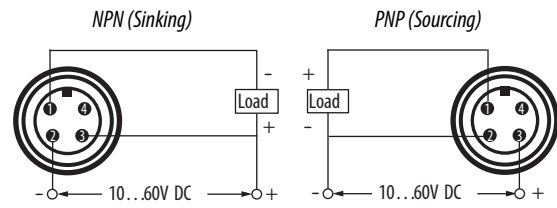

Normally Open or Normally Closed

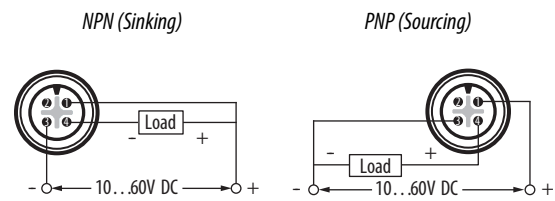

ATTENTION: Unit must be mounted to a grounded metal frame or grounded via field wiring lug per NEC requirements. Recommended grounding lug is included with the mounting kit (catalog number 871A-PKIT).

871D 3-wire DC Cylinder Sensors

Cylinder Position Inductive Style



871D DC Mini
Quick-disconnect Style 12 mm



871D DC Micro
Quick-disconnect Style 12 mm

Specifications

Attribute	871D
Outputs	Normally open
Load Current, Max.	<200 mA
Load Current, Nom.	≤10 mA (non-activated), ≤18 mA (activated)
Leakage Current	<80 μA
Operating Voltage	10...30V DC
Voltage Drop	<2.5V DC @ 200 mA
Switching Frequency	10 Hz
Repeatability	5% typical
Hysteresis	15% typical
Protection Type	Reverse polarity, false pulse, transient noise, short circuit, and overload
Weld Field Immunity	20,000 A @ 1 in.
Certifications	c-UL-us Listed and CE Marked for all applicable directives
Enclosure Type Rating	NEMA 1, 2, 3, 3R, 4, 6, 12, 13; IP67 (IEC 529)
Connection Type	Quick Disconnect: 4-pin mini style, 4-pin micro style
Status Indicator	<ul style="list-style-type: none"> Green: Power Orange: Output
Operating Temperature	-25...+70 °C (-13...+158 °F)
Shock	30 g (1.06 oz), 11 ms
Vibration	55 Hz, 1 mm amplitude, 3 planes
Housing Material	Machined aluminum
Probe Material	Stainless steel, ceramic face

Approximate Dimensions [mm (in.)]

Mini-connector Models

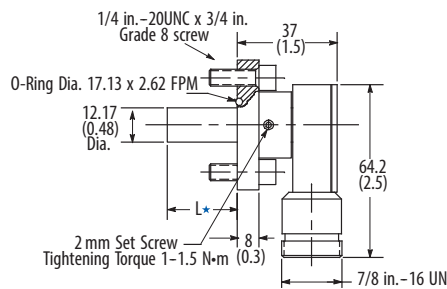
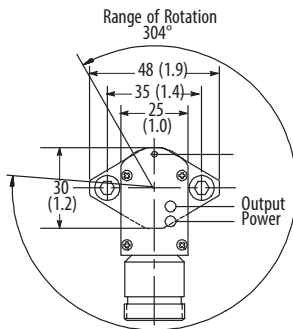

Micro-connector Models

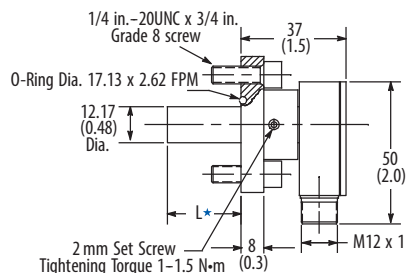
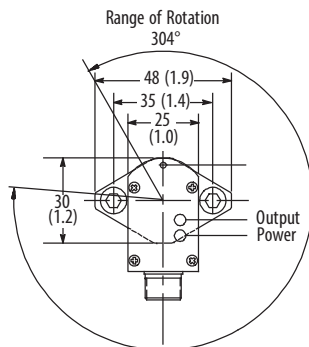

Wiring Diagrams

Normally Open

NPN (Sinking)

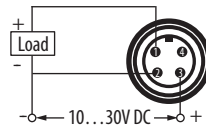

Normally Open

PNP (Sourcing)

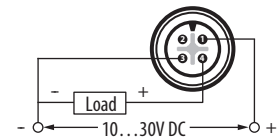

L* = Probe length varies by catalog number. See Product Selection tab on <http://ab.rockwellautomation.com>.

871D 2-wire AC/DC Cylinder Sensors

Cylinder Position Inductive Style



871D DC Mini
Quick-disconnect Style 12 mm



871D DC Micro
Quick-disconnect Style 12 mm

Specifications

Attribute	871D
Outputs	Normally open
Load Current	5...400 mA
Inrush Current (one cycle)	<3 A (t < 20 msec)
Leakage Current	<1.7 mA @ 120V AC
Operating Voltage	20...250V AC/DC
Voltage Drop	<6V @ 400 mA
Switching Frequency	50 Hz
Repeatability	5% typical
Hysteresis	15% typical
Protection Type	False pulse, transient noise, short circuit, and overload
Weld Field Immunity	20,000 A @ 1 in.
Certifications	c-UL-us Listed and CE Marked for all applicable directives
Enclosure Type Rating	NEMA 1, 2, 3, 3R, 4, 6, 12, 13; IP67 (IEC 529)
Connection Type	Quick Disconnect: 3-pin mini style, 3-pin micro style
Status Indicator	<ul style="list-style-type: none"> • Green: Power • Orange: Output
Operating Temperature	-25...+70 °C (-13...+158 °F)
Shock	30 g (1.06 oz), 11 ms
Vibration	55 Hz, 1 mm amplitude, 3 plane

Approximate Dimensions [mm (in.)]

Mini-connector Models

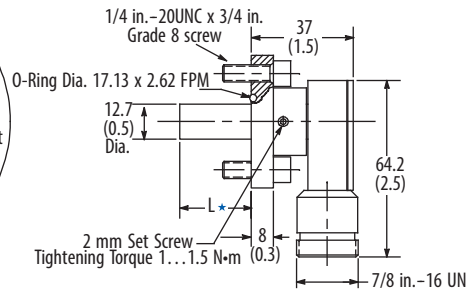
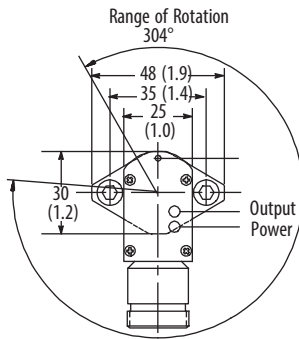

Wiring Diagrams

Normally Open

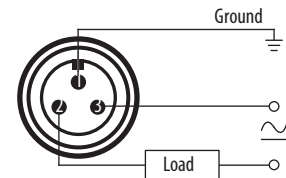

Micro-connector Models

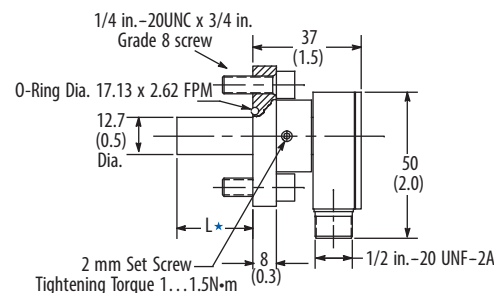
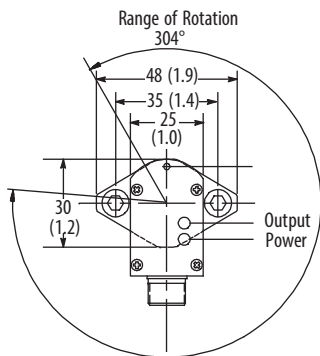

Normally Open or Normally Closed

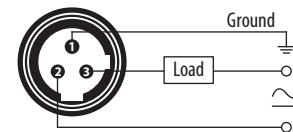

L* = Probe length varies by catalog number. See Product Selection tab on <http://ab.rockwellautomation.com>.

871D DC WorldClamp™ Cylinder Sensors

Power Clamp and Gripper Style



Bul.871D DC - Small Chicklet
100 mm, 165 mm, and 200 mm



Bul.871D DC - Large Chicklet
100 mm, 165 mm, and 200 mm



Bul.871D DC - Cylindrical Chicklet
100 mm

Specifications

Attribute	871D
Load Current	150 mA max
Leakage Current	<10 µA
Operating Voltage	10...30V DC
Voltage Drop	<2.5V
Repeatability	<2%
Hysteresis	5% typical
Protection Type	False pulse, transient noise, short circuit, and overload
Weld Field Immunity	1600 Gauss
Certifications	c-UL-us Listed and CE Marked for all applicable directives
Enclosure Type Rating	IP67
Connection Type	4-pin micro quick-disconnect
Status Indicator	<ul style="list-style-type: none"> Green: Power Orange: S1 output Red: S2 output
Operating Temperature	-25...+70 °C (-13...+158 °F)
Shock	30 g (1.06 oz), 11 ms
Vibration	55 Hz, 1 mm amplitude, 3 planes

Approximate Dimensions [mm (in.)]

Front View

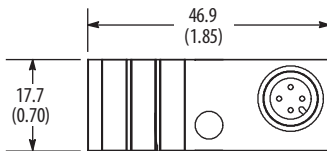

Large Chicklet

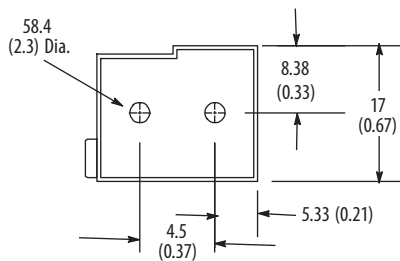
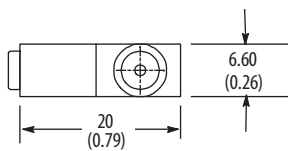

Side View

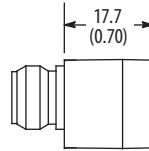

Small Chicklet

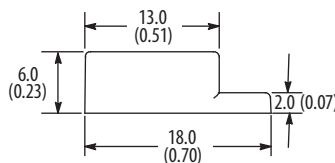
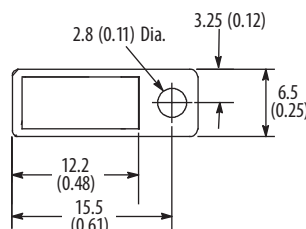

Cylindrical Chicklet

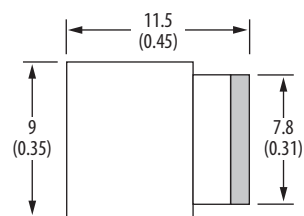

Wiring Diagrams

Normally Open
PNP (Sourcing)

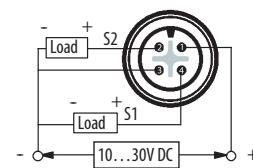

871D AC/DC WorldClamp Cylinder Sensors

Power Clamp and Gripper Style



Bul.871D AC/DC - Small Chicklet
100 mm, 165 mm, and 200 mm



Bul.871D AC/DC - Large Chicklet
100 mm, 165 mm, and 200 mm

Specifications

Attribute	871D
Load Current	100 mA max
Inrush Current	≤2 A (one cycle)
Leakage Current	<1.7 mA
Operating Voltage	20...150V AC/DC
Voltage Drop	<10V
Repeatability	<2%
Hysteresis	5% typical
Protection Type	False pulse, transient noise, short circuit, and overload
Weld Field Immunity	1600 Gauss
Certifications	c-UL-us Listed and CE Marked for all applicable directives
Enclosure Type Rating	IP67
Connection Type	5-pin AC micro quick-disconnect
Status Indicator	<ul style="list-style-type: none"> Two green: power S1 and S2 Orange: S1 output Red: S2 output
Operating Temperature	-25...+70 °C (-13...+158 °F)
Shock	30 g (1.06 oz), 11 ms
Vibration	55 Hz, 1 mm amplitude, 3 planes

Approximate Dimensions [mm (in.)]

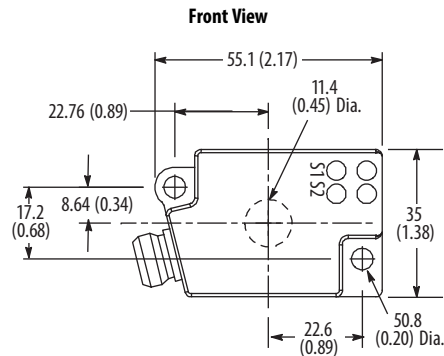

Side View

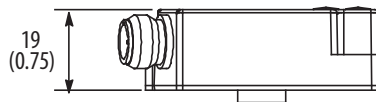

Large Chicklet

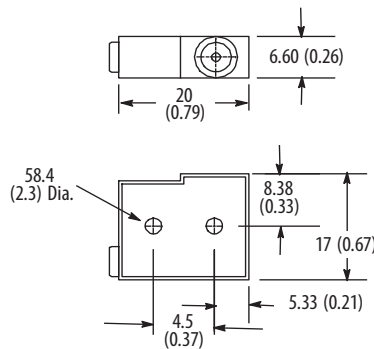

Small Chicklet

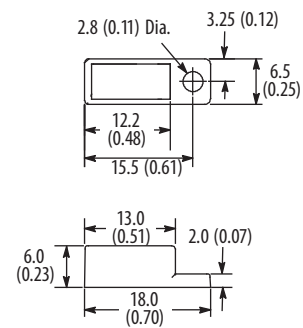

Wiring Diagrams

Normally Open

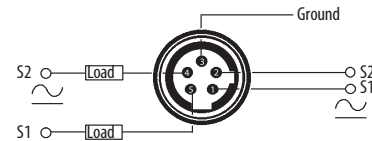

Bulletin 871R 3-wire DC Ring Sensors

Ring Style



Bul.871R DC Cable Style
12 mm and 20 mm



Bul.871R DC Micro
Quick-disconnect Style
50 mm



Bul.871R DC Micro
Quick-disconnect Style
50 mm

Specifications

Attribute	871R
Load Current	≤200 mA
Leakage Current	≤10 μA
Operating Voltage	10...30V DC
Voltage Drop	≤2.4V
Repeatability	≤2%
Hysteresis	10% typical
Protection Type	Reverse polarity, transient noise, short circuit, overload, and false pulse
Certifications	CE Marked for all applicable directives
Enclosure Type Rating	NEMA 4, IP67 (IEC 529)
Connection Type	<ul style="list-style-type: none"> Cable: 2 m (6.6 ft.) length 3-conductor #26 AWG PVC Quick-disconnect: 4-pin micro style
Indicator Status Indicators	Red: Output energized
Operating Temperature	-25...+70 °C (-13...+158 °F)
Shock	5 g (0.18 oz)
Vibration	10...55 Hz

Approximate Dimensions [mm (in.)]

Cable Style (Cat.871R-D12NP39-E2)

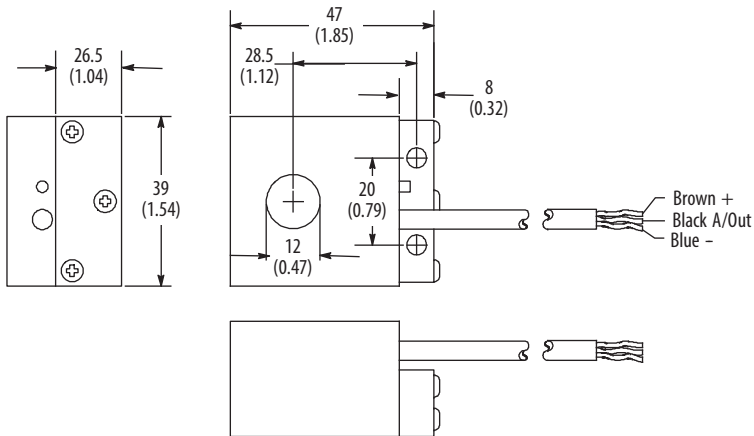

Wiring Diagrams

Normally Open

PNP (Sourcing)

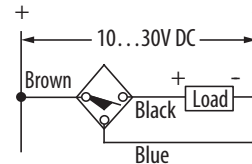

Approximate Dimensions [mm (in.)]

Cable Style (Cat.871R-D20NP73-E2)

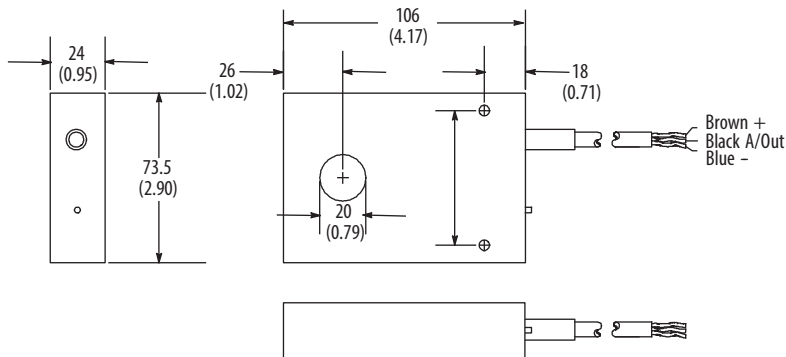

Wiring Diagrams

Normally Open

PNP (Sourcing)

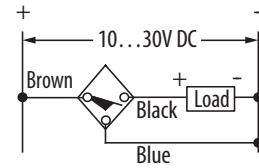

Micro Quick-disconnect Style(871R-D50N90-D4 and 871R-D50NN90-D4)

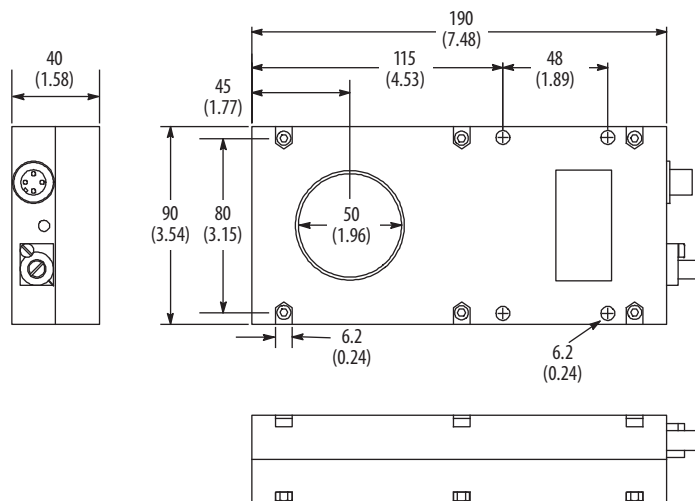

Complementary Normally Open and Normally Closed

PNP (Sourcing)

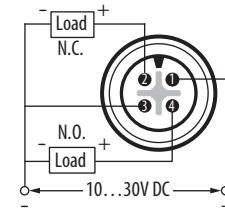

Micro Quick-disconnect Style(871R-D100NP120-D4 and 871R-D100NN120-D4)

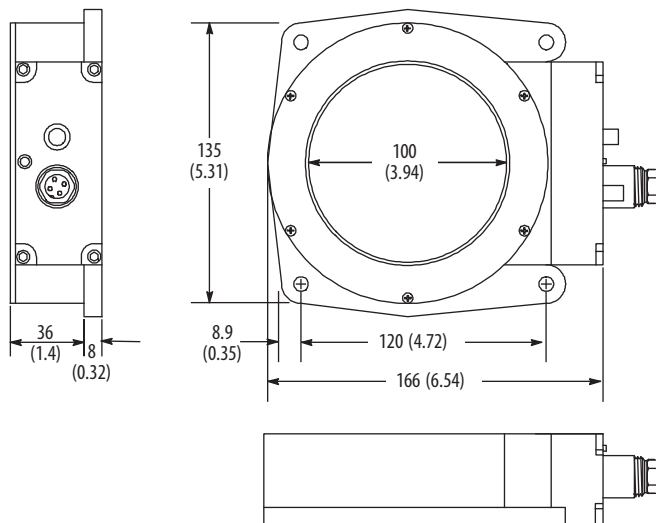

Complementary Normally Open and Normally Closed

PNP (Sourcing)

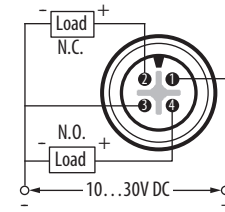

Bulletin 871S 3-wire DC Slot Sensors

Slot Style



871S DC Cable Style
30 mm Slot

Specifications

Attribute	871S
Load Current	≤200 mA
Leakage Current	≤10 μA
Operating Voltage	18...30V DC
Voltage Drop	≤2.4V
Repeatability	≤2%
Hysteresis	15% typical
Protection Type	Transient noise and false pulse
Certifications	CE Marked for all applicable directives
Enclosure Type Rating	NEMA 4; IP65 (IEC 529)
Connection Type	Cable: 2 m (6.6 ft) length, 3-conductor #26 AWG PVC
Indicator Status Indicators	None
Operating Temperature	-25...+70 °C (-13...+158 °F)
Shock	5 g (0.18 oz)
Vibration	10...55 Hz

Approximate Dimensions [mm (in.)]

Cable Style

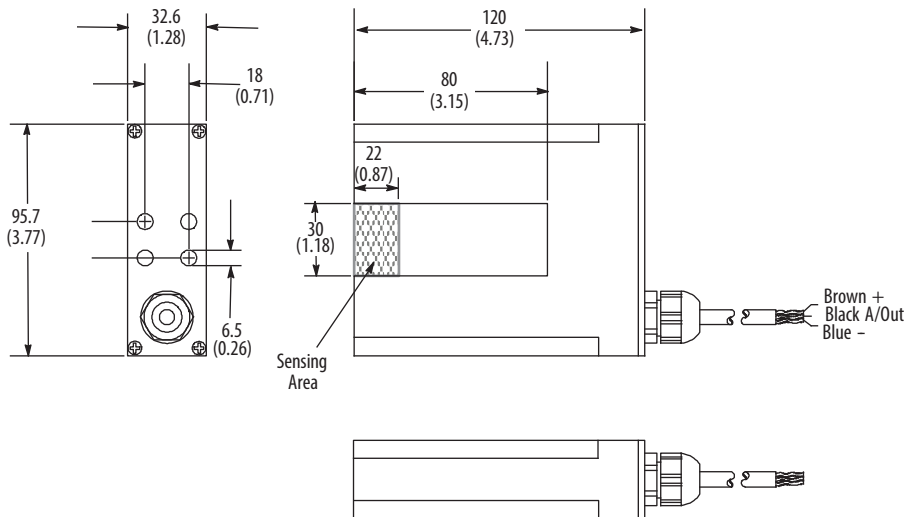

Wiring Diagrams

Normally Open

PNP (Sourcing)

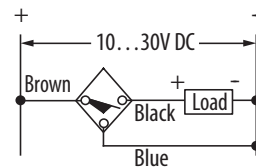

Notes:

Rockwell Automation Support

Use the following resources to access support information.

Technical Support Center	Knowledgebase Articles, How-to Videos, FAQs, Chat, User Forums, and Product Notification Updates.	www.rockwellautomation.com/knowledgebase
Local Technical Support Phone Numbers	Locate the phone number for your country.	www.rockwellautomation.com/global/support/get-support-now.page
Direct Dial Codes	Find the Direct Dial Code for your product. Use the code to route your call directly to a technical support engineer.	www.rockwellautomation.com/global/support/direct-dial.page
Literature Library	Installation Instructions, Manuals, Brochures, and Technical Data.	www.rockwellautomation.com/literature
Product Compatibility and Download Center (PCDC)	Get help determining how products interact, check features and capabilities, and find associated firmware.	www.rockwellautomation.com/global/support/pcdc.page

Documentation Feedback

Your comments will help us serve your documentation needs better. If you have any suggestions on how to improve this document, complete the How Are We Doing? form at http://literature.rockwellautomation.com/idc/groups/literature/documents/du/ra-du002_-en-e.pdf.

Rockwell Automation maintains current product environmental information on its website at <http://www.rockwellautomation.com/rockwellautomation/about-us/sustainability-ethics/product-environmental-compliance.page>.

Allen-Bradley, LISTEN. THINK. SOLVE, Pico, Rockwell Automation, Rockwell Software, ToughCoat Finish, ToughLink, VersaCube, WorldClamp, and WorldProx are trademarks of Rockwell Automation, Inc. Trademarks not belonging to Rockwell Automation are property of their respective companies.

Rockwell Otomasyon Ticaret A.Ş., Kar Plaza İş Merkezi E Blok Kat:6 34752 İçerenköy, İstanbul, Tel: +90 (216) 5698400

www.rockwellautomation.com

Power, Control and Information Solutions Headquarters

Americas: Rockwell Automation, 1201 South Second Street, Milwaukee, WI 53204-2496 USA, Tel: (1) 414.382.2000, Fax: (1) 414.382.4444
Europe/Middle East/Africa: Rockwell Automation NV, Pegasus Park, De Kleetlaan 12a, 1831 Diegem, Belgium, Tel: (32) 2 663 0600, Fax: (32) 2 663 0640
Asia Pacific: Rockwell Automation, Level 14, Core F, Cyberport 3, 100 Cyberport Road, Hong Kong, Tel: (852) 2887 4788, Fax: (852) 2508 1846

Publication PROX-TD001G-EN-P - June 2017

Supersedes Publication PROX-TD001F-EN-P - April 2017

Copyright © 2017 Rockwell Automation, Inc. All rights reserved. Printed in the U.S.A.